

**Nokia Customer Care**

# ***Service Manual***

**RM-346; RM-357; RM-407 (Nokia E71)**

## **Schematics**

***Part No: (Issue 1)***



***COMPANY CONFIDENTIAL***



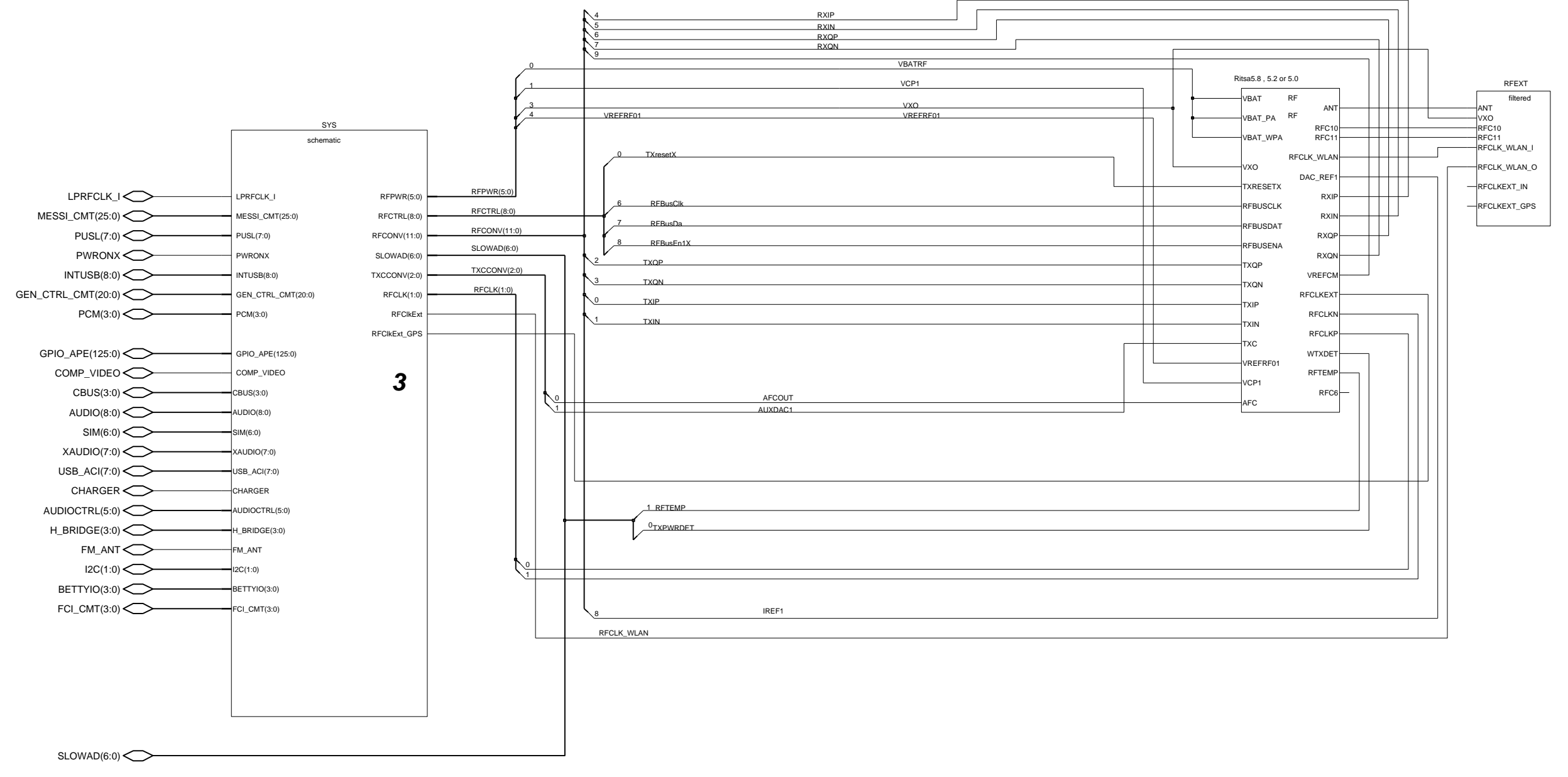
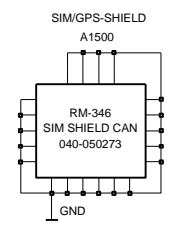
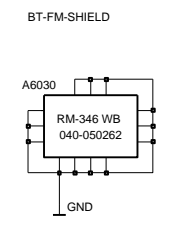
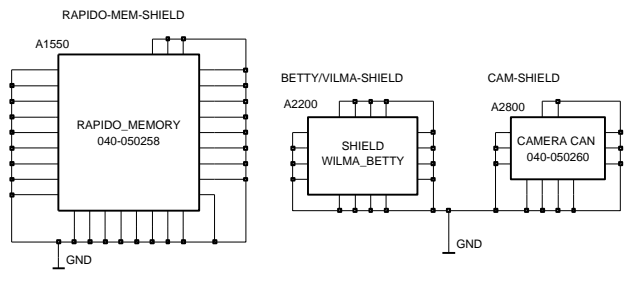

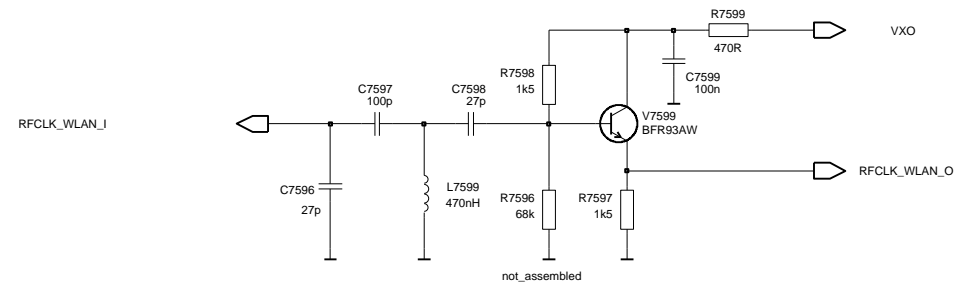
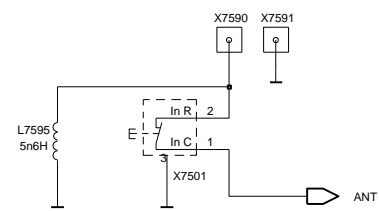



 RFC10  
 RFC11

Copyright (C) Nokia Corporation. All rights reserved.  
 THIS DRAWING IS PROTECTED BY COPYRIGHT AS AN UNPUBLISHED WORK.  
 UNAUTHORIZED REPRODUCTION OF THIS DRAWING IS NOT PERMITTED.  
 THIS DRAWING CONTAINS PROPRIETARY AND CONFIDENTIAL INFORMATION.  
 This document is property of Nokia Corporation



Name	RF EXT	Appr	dd-mmm-yy
Assoc		Des.	
File		Dr.	
Proj		Sheet XX of yy	0 (01)
	Draw.	Print Yes	V. 0,0 Edit 14

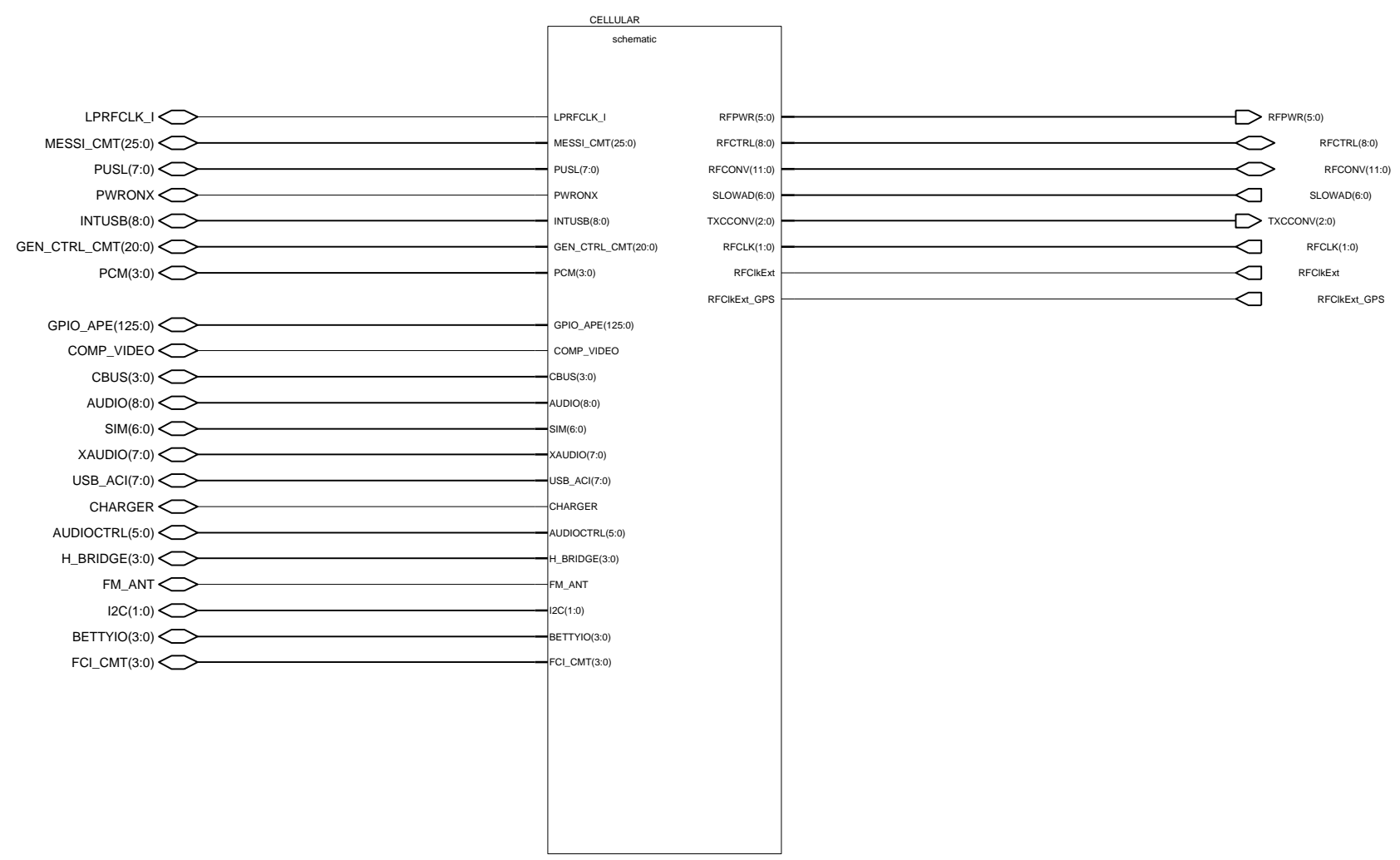

Copyright (C) Nokia Corporation. All rights reserved.  
 THIS DRAWING IS PROTECTED BY COPYRIGHT AS AN UNPUBLISHED WORK.  
 UNAUTHORIZED REPRODUCTION OF THIS DRAWING IS NOT PERMITTED.  
 THIS DRAWING CONTAINS PROPRIETARY AND CONFIDENTIAL INFORMATION.  
 This document is property of Nokia Corporation



Name	BB Top Level	Appr	dd-mmm-yy
Assoc	Build B 1.0	Des.	
File		Dr.	
Proj	Drw.	Sheet xx of yy	0 (01)
		Print Yes	v. 02 Edit 4

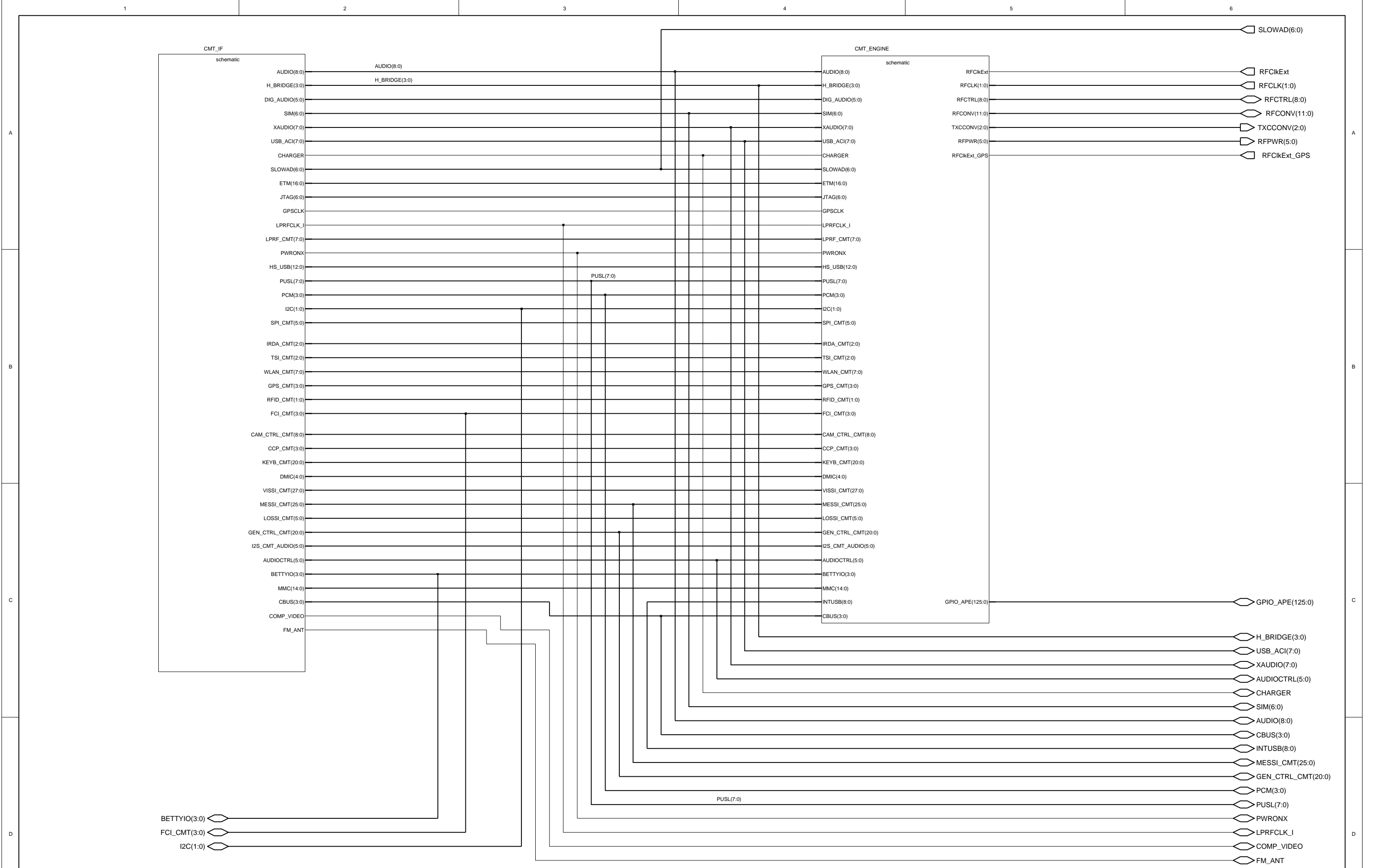

Copyright (C) Nokia Corporation. All rights reserved.  
 THIS DRAWING IS PROTECTED BY COPYRIGHT AS AN UNPUBLISHED WORK.  
 UNAUTHORIZED REPRODUCTION OF THIS DRAWING IS NOT PERMITTED.  
 THIS DRAWING CONTAINS PROPRIETARY AND CONFIDENTIAL INFORMATION.  
 This document is property of Nokia Corporation



Name	Cellular Top Level		Appr	dd-mmm-yy	
Assoc			Des.		
File			Dr.		
Proj			Sheet	xx of yy	0 (01)
			Print	Yes	v. 0 Edit 4

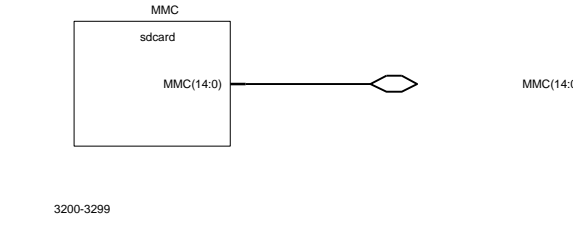
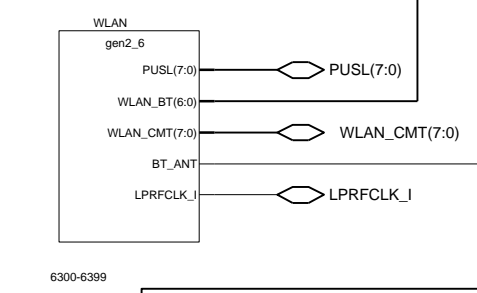
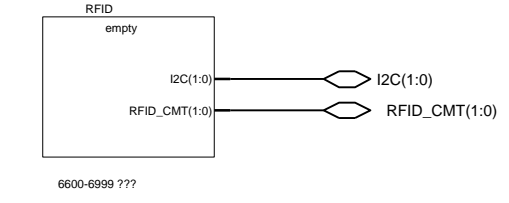
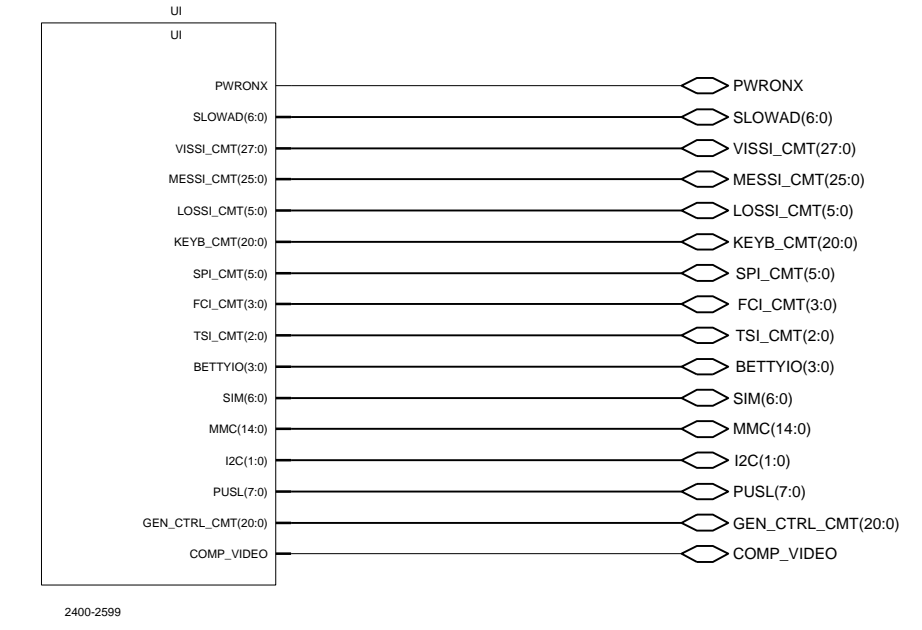
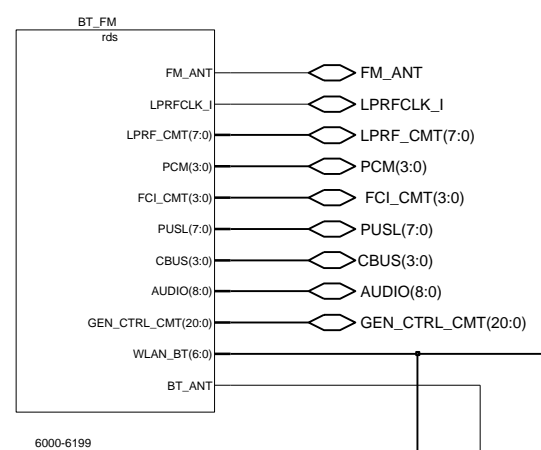
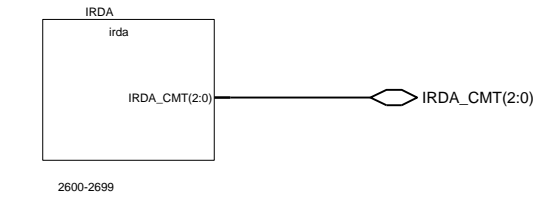
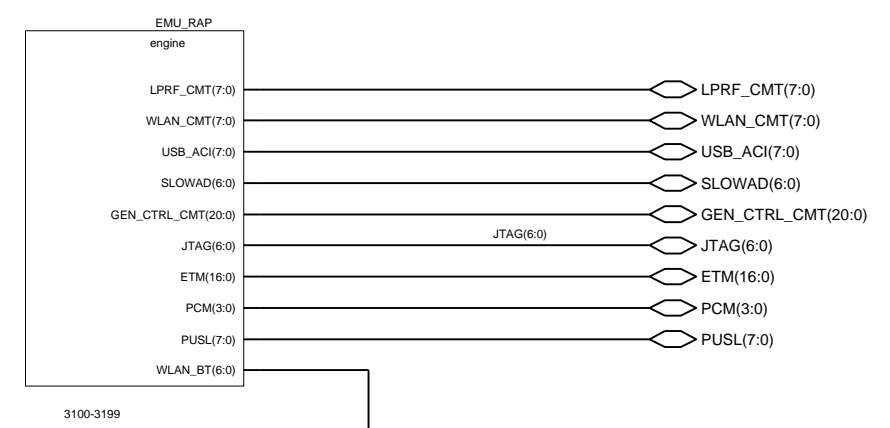
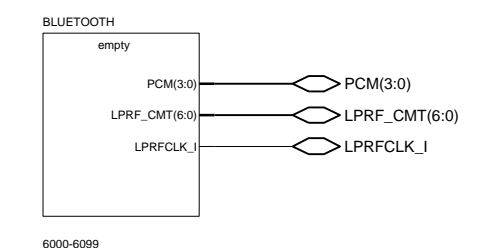
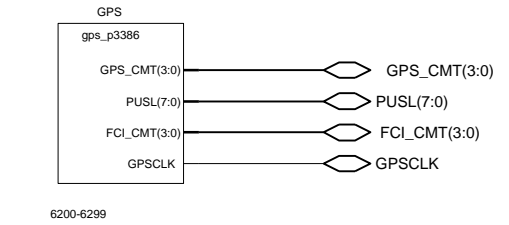
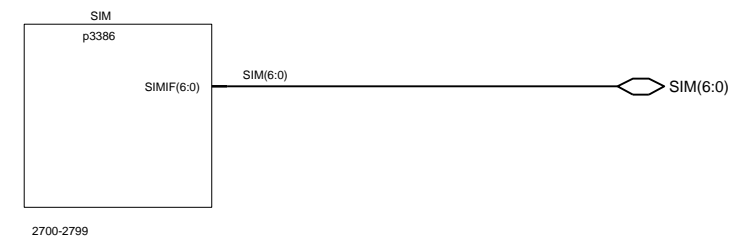
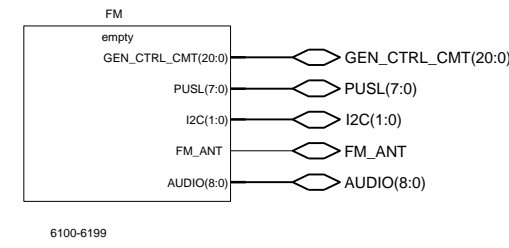
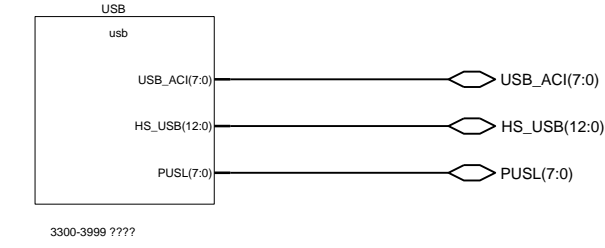
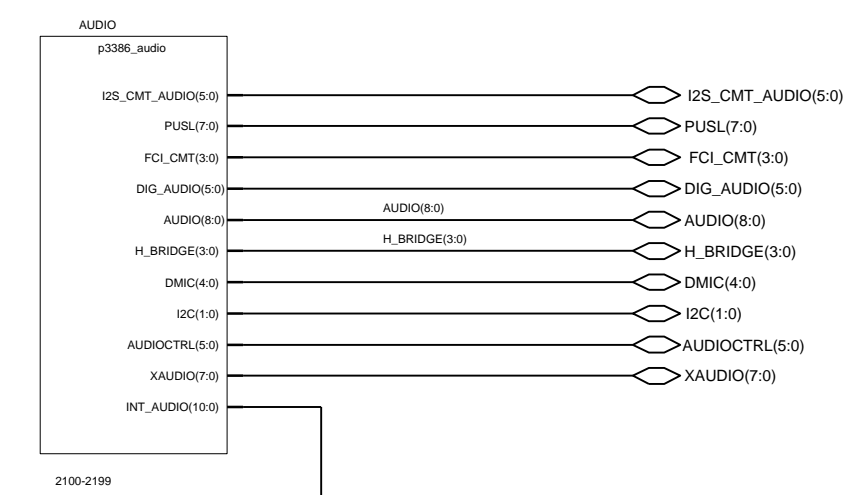
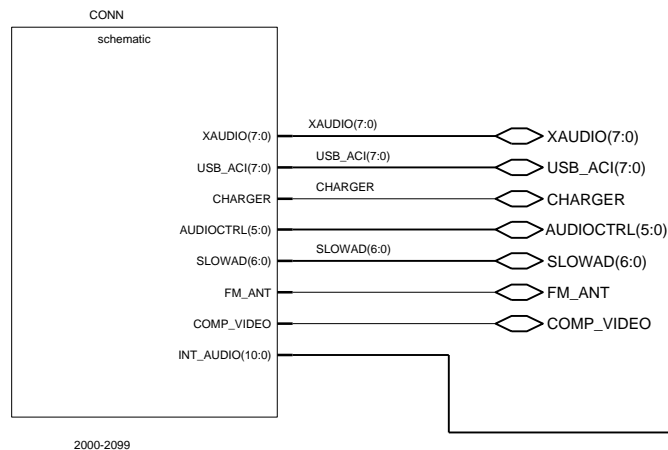
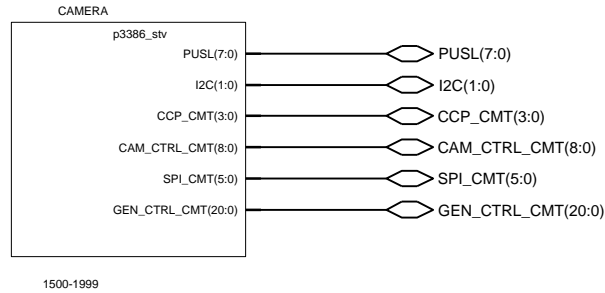
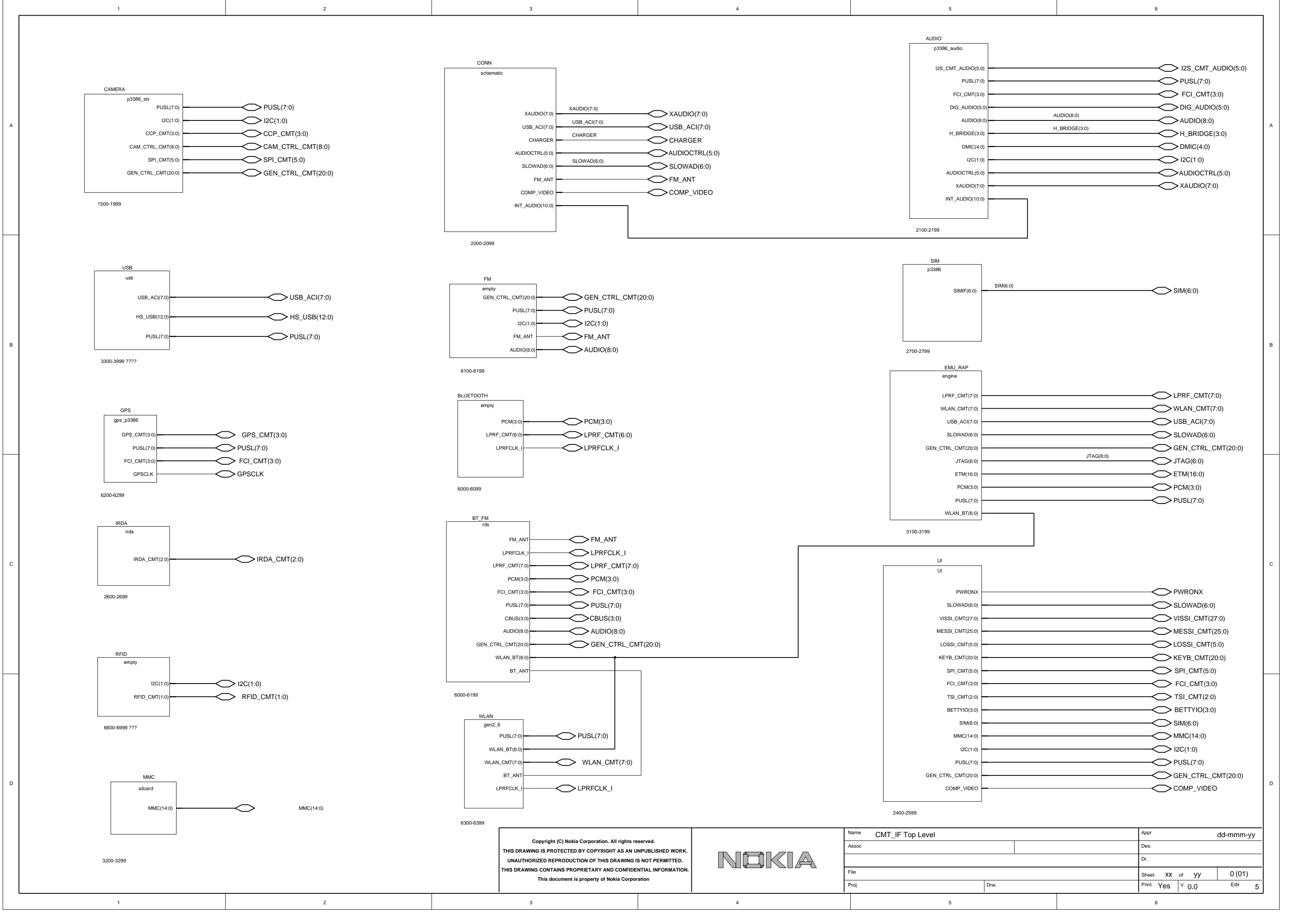

Copyright (C) Nokia Corporation. All rights reserved.  
THIS DRAWING IS PROTECTED BY COPYRIGHT AS AN UNPUBLISHED WORK.  
UNAUTHORIZED REPRODUCTION OF THIS DRAWING IS NOT PERMITTED.  
THIS DRAWING CONTAINS PROPRIETARY AND CONFIDENTIAL INFORMATION.  
This document is property of Nokia Corporation



Name CMT_IF Top Level		Appr dd-mmm-yy	
Assoc		Des.	
File		Dr.	
Proj		Sheet xx of yy	0 (01)
Print Yes		V. 0,0	Edit 5

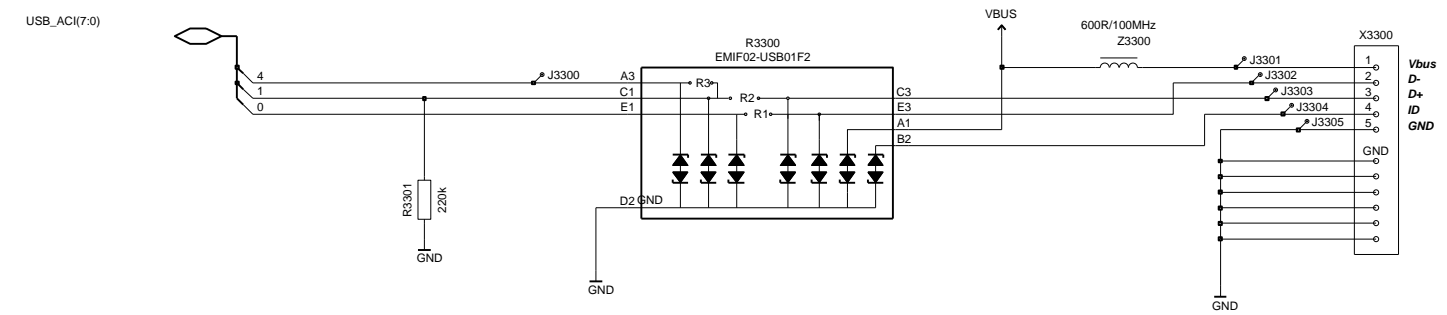

USB\_ACI(7:0)

HS\_USB(12:0)

PUSL(7:0)

Copyright (C) Nokia Corporation. All rights reserved.  
 THIS DRAWING IS PROTECTED BY COPYRIGHT AS AN UNPUBLISHED WORK.  
 UNAUTHORIZED REPRODUCTION OF THIS DRAWING IS NOT PERMITTED.  
 THIS DRAWING CONTAINS PROPRIETARY AND CONFIDENTIAL INFORMATION.  
 This document is property of Nokia Corporation



Name	Standard USB	Appr	dd-mmm-yy
Assoc		Des.	
File		Dr.	
Proj		Sheet xx of yy	0 (01)
		Print Yes	v. 0.0 Edit 5

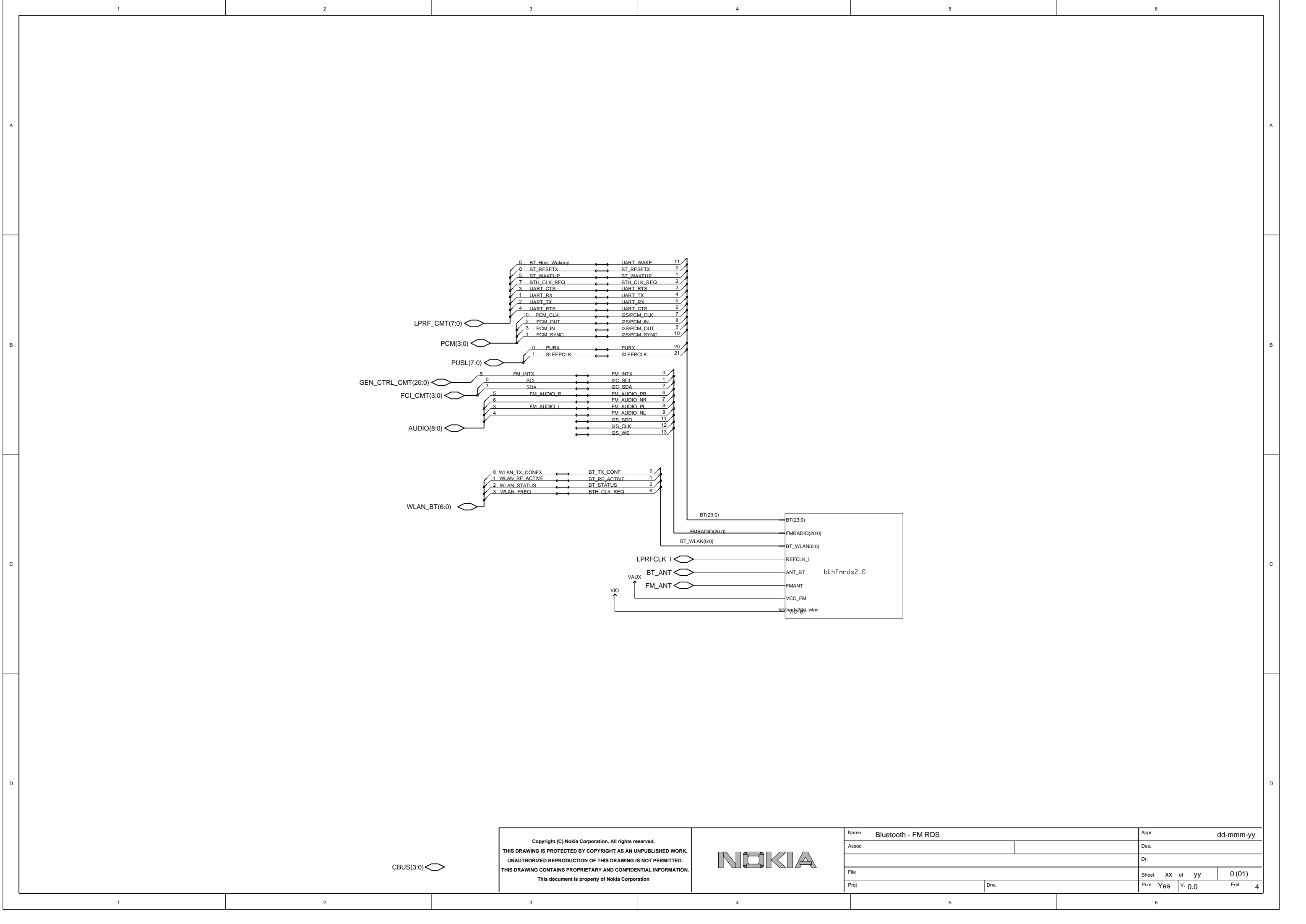

Copyright (C) Nokia Corporation. All rights reserved.  
 THIS DRAWING IS PROTECTED BY COPYRIGHT AS AN UNPUBLISHED WORK.  
 UNAUTHORIZED REPRODUCTION OF THIS DRAWING IS NOT PERMITTED.  
 THIS DRAWING CONTAINS PROPRIETARY AND CONFIDENTIAL INFORMATION.  
 This document is property of Nokia Corporation



Name	Bluetooth - FM RDS	Appr	dd-mmm-yy
Assoc		Des.	
File		Dr.	
Proj		Sheet xx of yy	0 (01)
		Print Yes	v. 0.0 Edit 4

CBUS(3:0)

# BLUETOOTH & FM RADIO DISCRETE

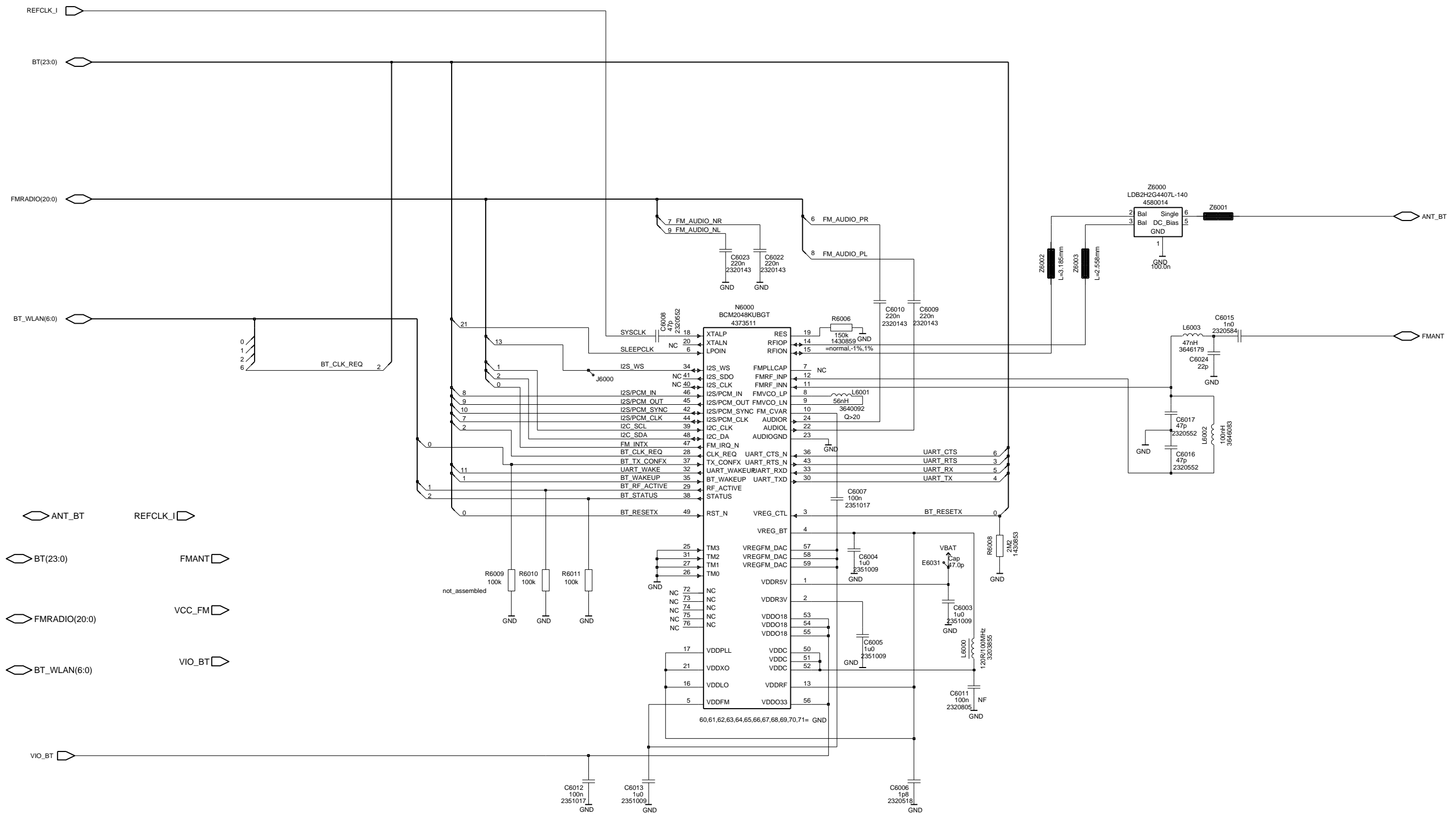

**Notes.**

- 1) 3k3 Pull-up Resistors are required on I2C\_SCL & I2C\_SDA
- 2) Additional test components fo phone wing boards are given in BTHfmrds2.0\_Test Schematic
- 3) E6033 will be used in future release for 1.8V operation.
- 4) A pull down is required on the CLK\_REQ signal (see release note).

<p>Copyright (C) Nokia Corporation. All rights reserved.                  THIS DRAWING IS PROTECTED BY COPYRIGHT AS AN UNPUBLISHED WORK.                  UNAUTHORIZED REPRODUCTION OF THIS DRAWING IS NOT PERMITTED.                  THIS DRAWING CONTAINS PROPRIETARY AND CONFIDENTIAL INFORMATION.                  This document is property of Nokia Corporation</p>		<table border="1" style="width: 100%; border-collapse: collapse;"> <tr> <td colspan="2">Name</td> <td colspan="2">bthfmrds_2_0D</td> <td colspan="2">Appr</td> <td colspan="2">dd-mmm-yy</td> </tr> <tr> <td colspan="2">Assoc</td> <td colspan="2"></td> <td colspan="2">Des.</td> <td colspan="2"></td> </tr> <tr> <td colspan="2">File</td> <td colspan="2"></td> <td colspan="2">Dr.</td> <td colspan="2"></td> </tr> <tr> <td colspan="2">Proj</td> <td colspan="2"></td> <td colspan="2">Sheet</td> <td colspan="2">xx of yy</td> </tr> <tr> <td colspan="2"></td> <td colspan="2"></td> <td colspan="2">Print</td> <td colspan="2">Yes</td> </tr> <tr> <td colspan="2"></td> <td colspan="2"></td> <td colspan="2">V.</td> <td colspan="2">0,0</td> </tr> <tr> <td colspan="2"></td> <td colspan="2"></td> <td colspan="2">Edit</td> <td colspan="2">12</td> </tr> </table>	Name		bthfmrds_2_0D		Appr		dd-mmm-yy		Assoc				Des.				File				Dr.				Proj				Sheet		xx of yy						Print		Yes						V.		0,0						Edit		12	
Name		bthfmrds_2_0D		Appr		dd-mmm-yy																																																				
Assoc				Des.																																																						
File				Dr.																																																						
Proj				Sheet		xx of yy																																																				
				Print		Yes																																																				
				V.		0,0																																																				
				Edit		12																																																				

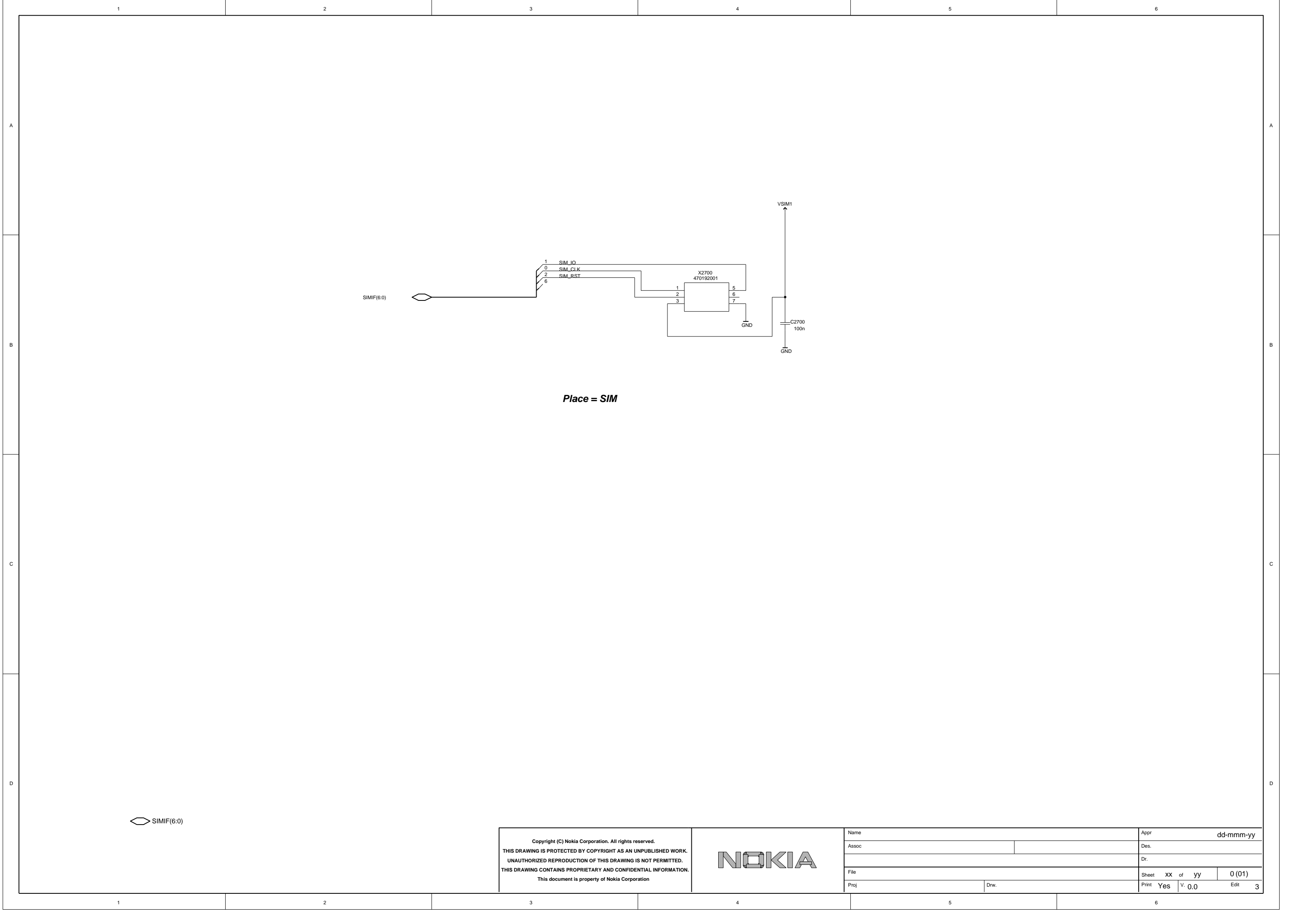

SIMIF(6:0)

Copyright (C) Nokia Corporation. All rights reserved.  
 THIS DRAWING IS PROTECTED BY COPYRIGHT AS AN UNPUBLISHED WORK.  
 UNAUTHORIZED REPRODUCTION OF THIS DRAWING IS NOT PERMITTED.  
 THIS DRAWING CONTAINS PROPRIETARY AND CONFIDENTIAL INFORMATION.  
 This document is property of Nokia Corporation



Name	Appr	dd-mmm-yy
Assoc	Des.	
Dr.		
File	Sheet xx of yy	0 (01)
Proj	Print Yes	v. 0.0 Edit 3

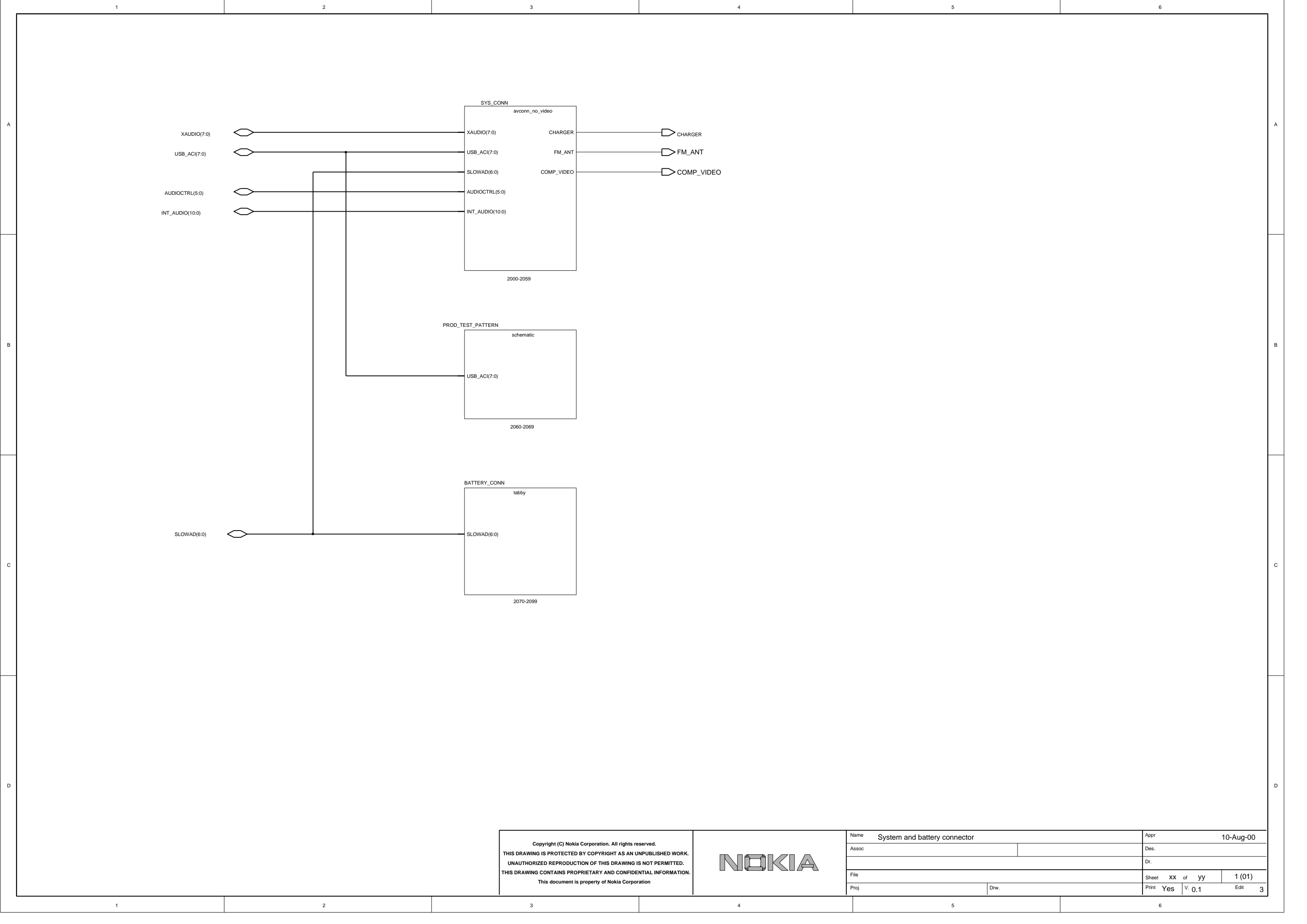

Copyright (C) Nokia Corporation. All rights reserved.  
 THIS DRAWING IS PROTECTED BY COPYRIGHT AS AN UNPUBLISHED WORK.  
 UNAUTHORIZED REPRODUCTION OF THIS DRAWING IS NOT PERMITTED.  
 THIS DRAWING CONTAINS PROPRIETARY AND CONFIDENTIAL INFORMATION.  
 This document is property of Nokia Corporation



Name	System and battery connector		Appr	10-Aug-00	
Assoc			Des.		
File			Dr.		
Proj			Sheet	xx of yy	1 (01)
			Print	Yes	V. 0,1 Edit 3

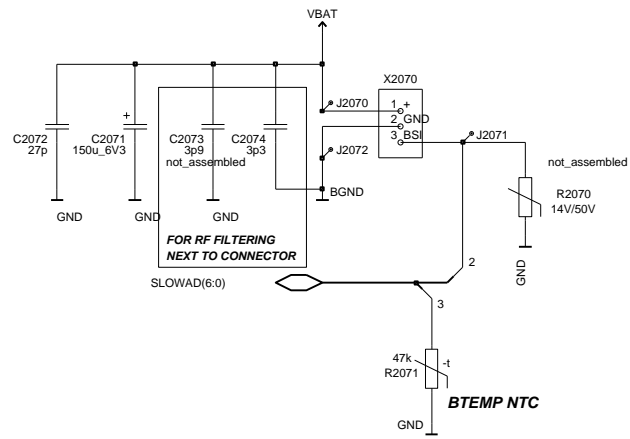

Copyright (C) Nokia Corporation. All rights reserved.  
 THIS DRAWING IS PROTECTED BY COPYRIGHT AS AN UNPUBLISHED WORK.  
 UNAUTHORIZED REPRODUCTION OF THIS DRAWING IS NOT PERMITTED.  
 THIS DRAWING CONTAINS PROPRIETARY AND CONFIDENTIAL INFORMATION.  
 This document is property of Nokia Corporation



Name	Battery Connector	Appr	10-Aug-00
Assoc	BUILD B1.0	Des.	
File		Dr.	
Proj	Drw.	Sheet XX of yy	1 (01)
		Print Yes v. 02	Edit 9

FOR VARIANT IDENTIFICATION

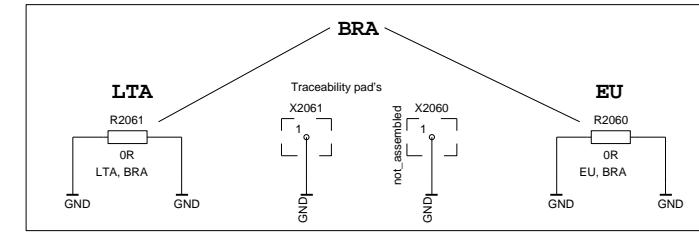

BB5.0 have defined 7-pin test pad pattern

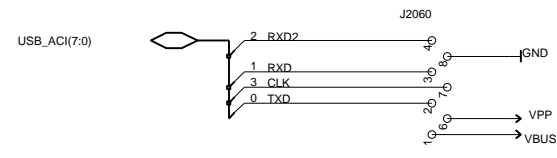

Copyright (C) Nokia Corporation. All rights reserved.  
 THIS DRAWING IS PROTECTED BY COPYRIGHT AS AN UNPUBLISHED WORK.  
 UNAUTHORIZED REPRODUCTION OF THIS DRAWING IS NOT PERMITTED.  
 THIS DRAWING CONTAINS PROPRIETARY AND CONFIDENTIAL INFORMATION.  
 This document is property of Nokia Corporation



Name	Production test pad		Appr	10-Aug-00	
Assoc			Des.		
File			Dr.		
Proj			Sheet	xx of yy	1 (01)
			Print	Yes	V. 0,1 Edit 21

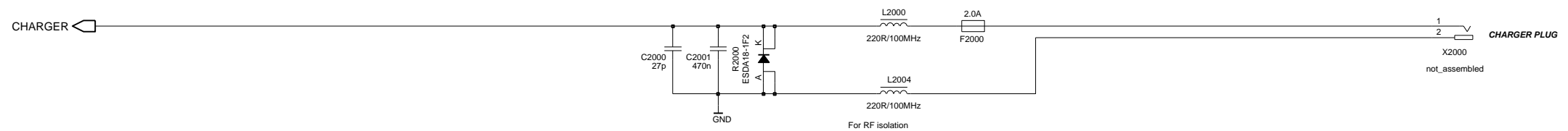

NOTE: This sheet requires AVILMA with external 2k bias resistor in VILMA sheet

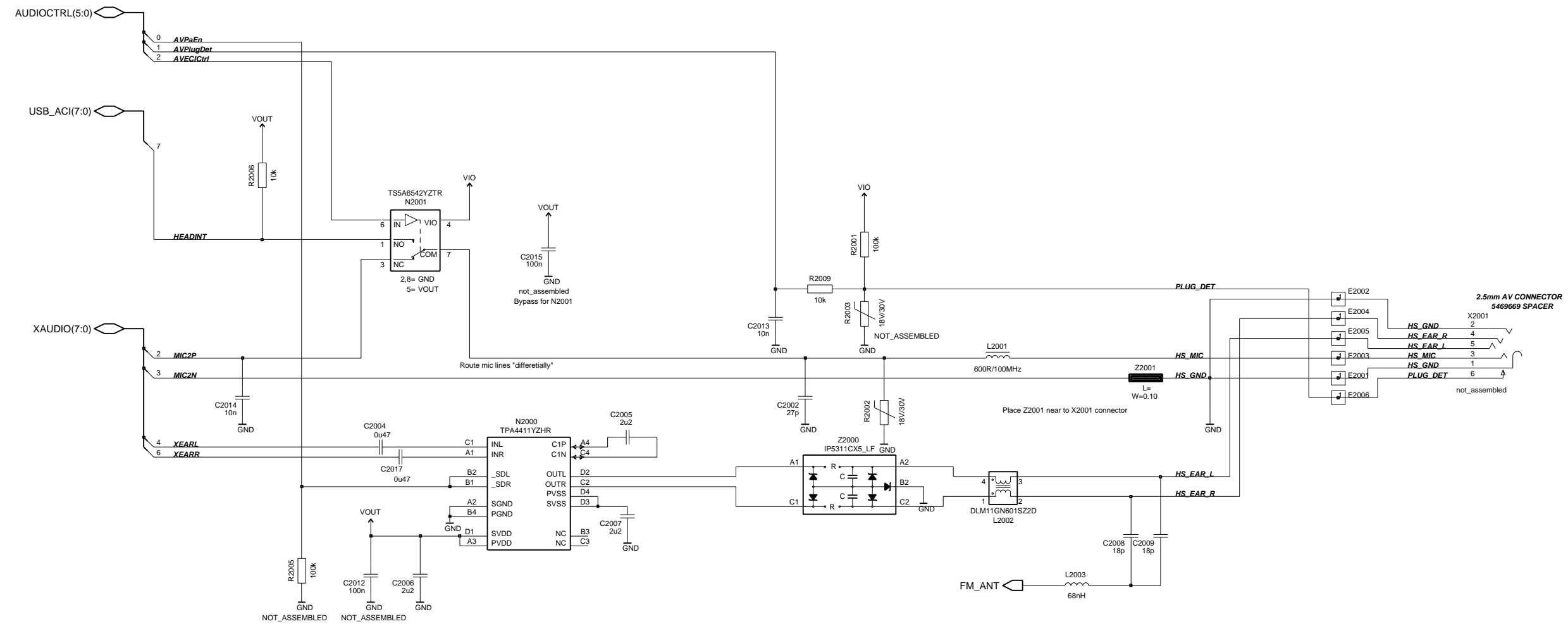

SLOWAD(6:0)  
INT\_AUDIO(10:0)  
COMP\_VIDEO

Copyright (C) Nokia Corporation. All rights reserved. THIS DRAWING IS PROTECTED BY COPYRIGHT AS AN UNPUBLISHED WORK. UNAUTHORIZED REPRODUCTION OF THIS DRAWING IS NOT PERMITTED. THIS DRAWING CONTAINS PROPRIETARY AND CONFIDENTIAL INFORMATION. This document is property of Nokia Corporation		<b>NOKIA</b>		Name AV connector		Appr dd-mmm-yy	
				Assoc		Des.	
				File		Dr.	
				Proj		Sheet xx of yy 0 (01)	
				Draw.		Print Yes v. 0,0 Edit 16	

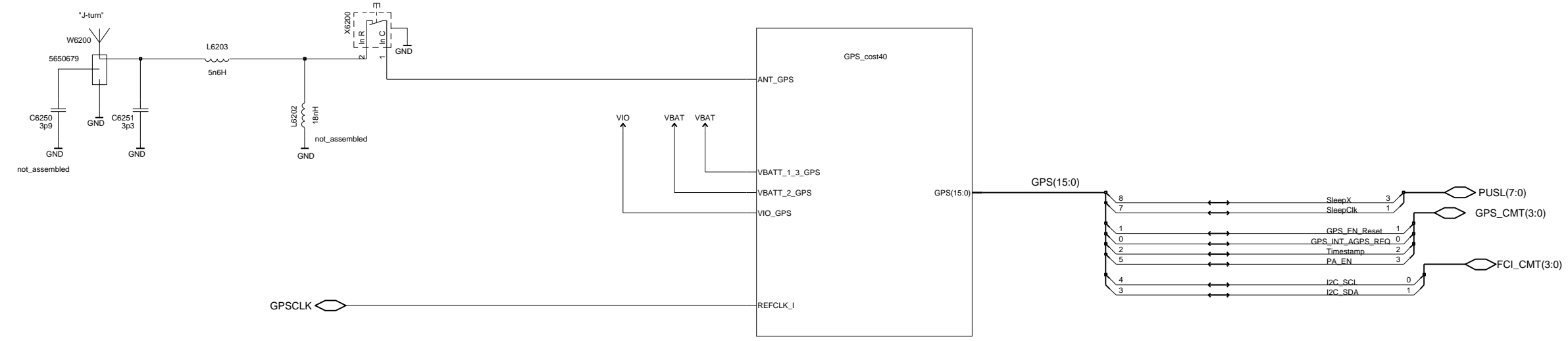

GPS\_CMT(3:0)

PUSL(7:0)

Test pad	Needed	Optional
J6200 GPS_EN_RESET	X	X
J6201 GPS_INT	X	X
J6202 IO_TIMESTAMP_DATARDY	X	X
J6203 GPS_PA_EN	X	X

FCI\_CMT(3:0)

GPSCLK

Copyright (C) Nokia Corporation. All rights reserved.  
 THIS DRAWING IS PROTECTED BY COPYRIGHT AS AN UNPUBLISHED WORK.  
 UNAUTHORIZED REPRODUCTION OF THIS DRAWING IS NOT PERMITTED.  
 THIS DRAWING CONTAINS PROPRIETARY AND CONFIDENTIAL INFORMATION.  
 This document is property of Nokia Corporation



Name	GPS	Appr	dd-mmm-yy
Assoc		Des.	
File		Dr.	
Proj		Sheet xx of yy	0 (01)
		Print Yes	v. 0,0 Edit 28

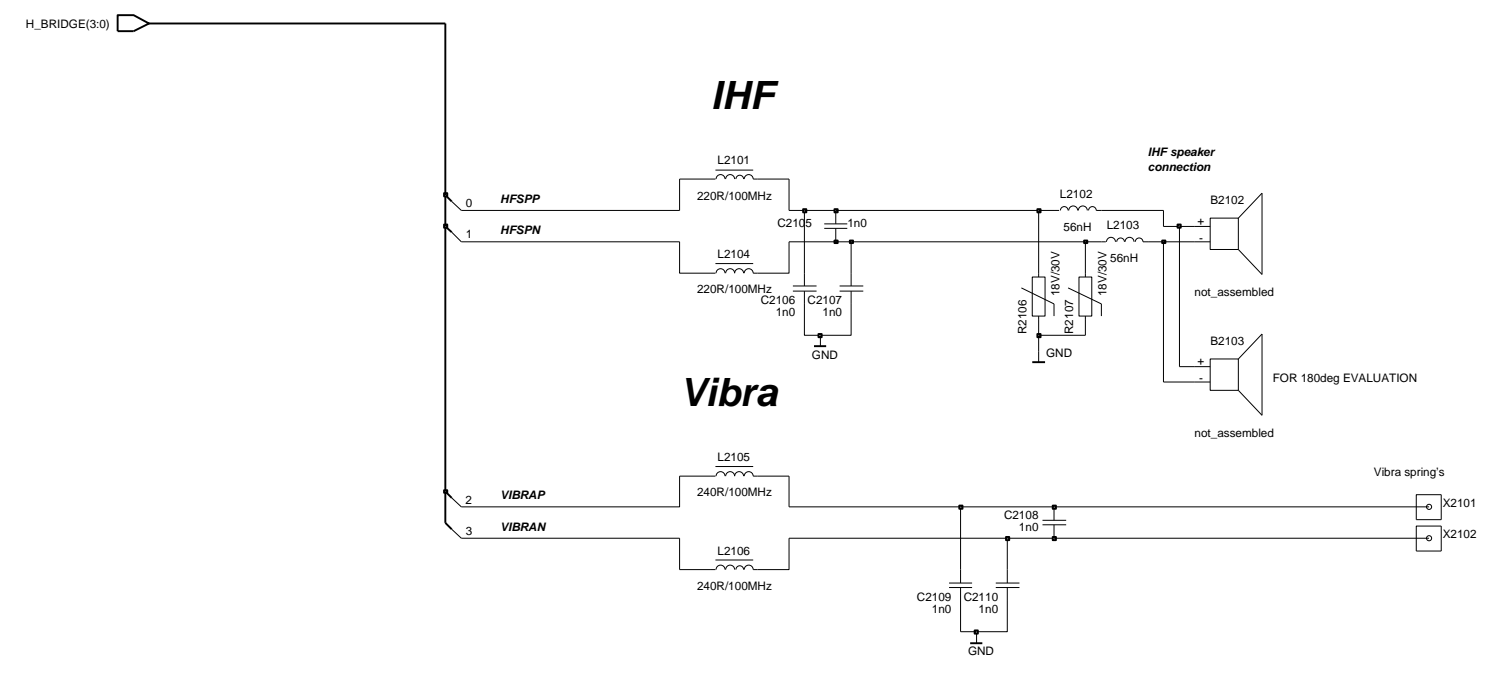
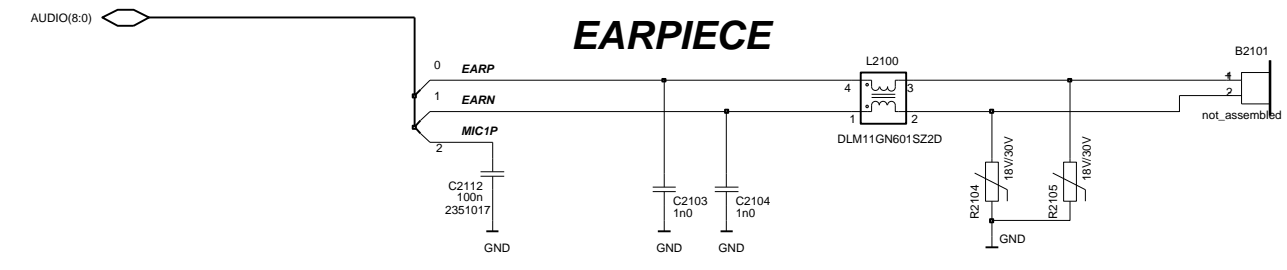
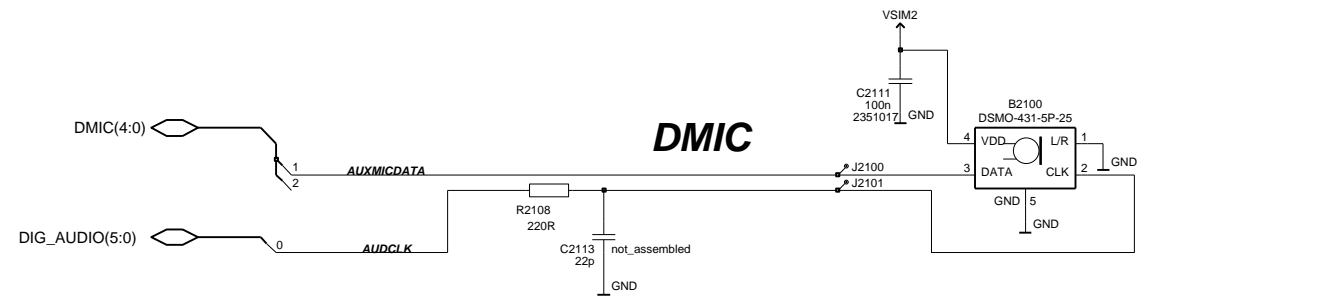

INT\_AUDIO(10:0)

I2S\_CMT\_AUDIO(5:0)

PUSL(7:0)

FCL\_CMT(3:0)

I2C(1:0)

AUDIOCTRL(5:0)

XAUDIO(7:0)

Copyright (C) Nokia Corporation. All rights reserved.  
 THIS DRAWING IS PROTECTED BY COPYRIGHT AS AN UNPUBLISHED WORK.  
 UNAUTHORIZED REPRODUCTION OF THIS DRAWING IS NOT PERMITTED.  
 THIS DRAWING CONTAINS PROPRIETARY AND CONFIDENTIAL INFORMATION.  
 This document is property of Nokia Corporation



Name		Appr	dd-mmm-yy
Assoc		Des.	
File		Dr.	
Proj		Sheet xx of yy	0 (01)
	Draw.	Print Yes	v. 0,0 Edit 12

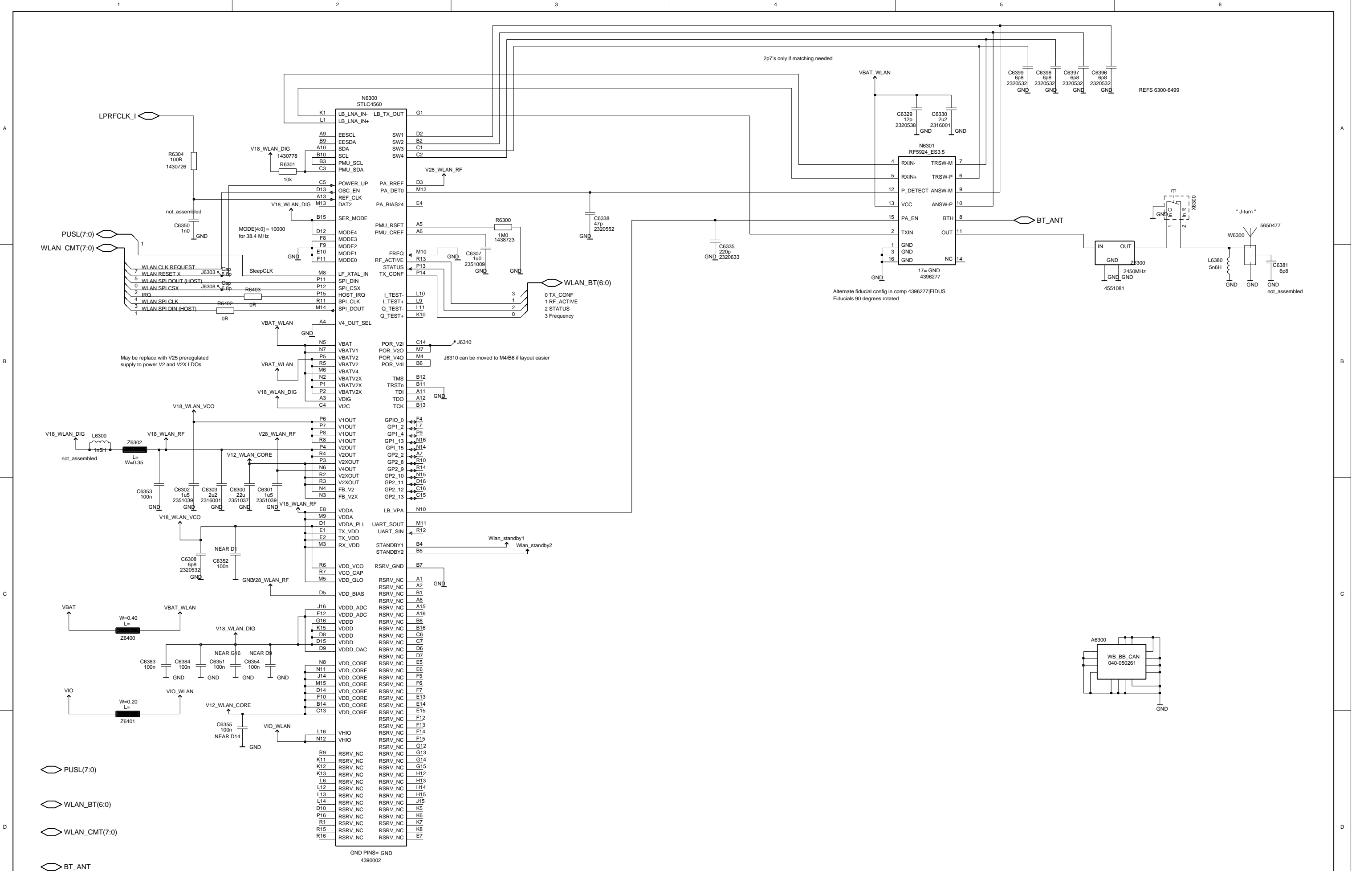

Copyright (C) Nokia Corporation. All rights reserved.  
 THIS DRAWING IS PROTECTED BY COPYRIGHT AS AN UNPUBLISHED WORK.  
 UNAUTHORIZED REPRODUCTION OF THIS DRAWING IS NOT PERMITTED.  
 THIS DRAWING CONTAINS PROPRIETARY AND CONFIDENTIAL INFORMATION.  
 This document is property of Nokia Corporation



Name	wlan_2_6	Appr	dd-mmm-yy
Assoc		Des.	
File		Dr.	
Proj		Sheet	xx of yy
		Print	Yes
		V.	0,0
		Edit	13

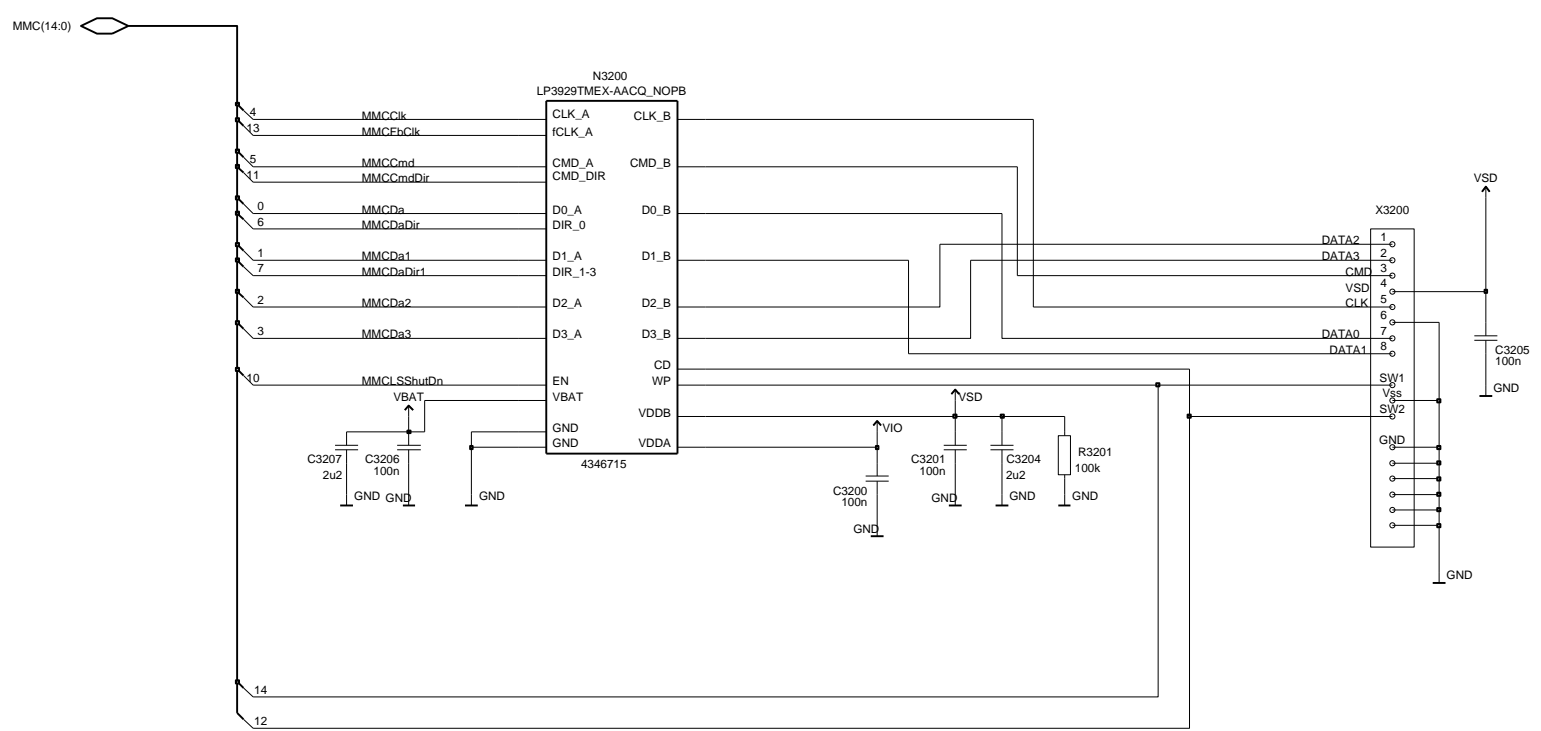

Copyright (C) Nokia Corporation. All rights reserved.  
 THIS DRAWING IS PROTECTED BY COPYRIGHT AS AN UNPUBLISHED WORK.  
 UNAUTHORIZED REPRODUCTION OF THIS DRAWING IS NOT PERMITTED.  
 THIS DRAWING CONTAINS PROPRIETARY AND CONFIDENTIAL INFORMATION.  
 This document is property of Nokia Corporation



Name	SD card	Appr	dd-mmm-yy
Assoc		Des.	
File		Dr.	
Proj		Sheet xx of yy	0 (01)
	Draw.	Print Yes	v. 0.0 Edit 4

A

B

C

D

A

B

C

D

I2C(1:0)

CCP\_CMT(3:0)

CAM\_CTRL\_CMT(8:0)

PUSL(7:0)

I2C(1:0)

CCP\_CMT(3:0)

CAM\_CTRL\_CMT(8:0)

SPI\_CMT(5:0)

GEN\_CTRL\_CMT(20:0)

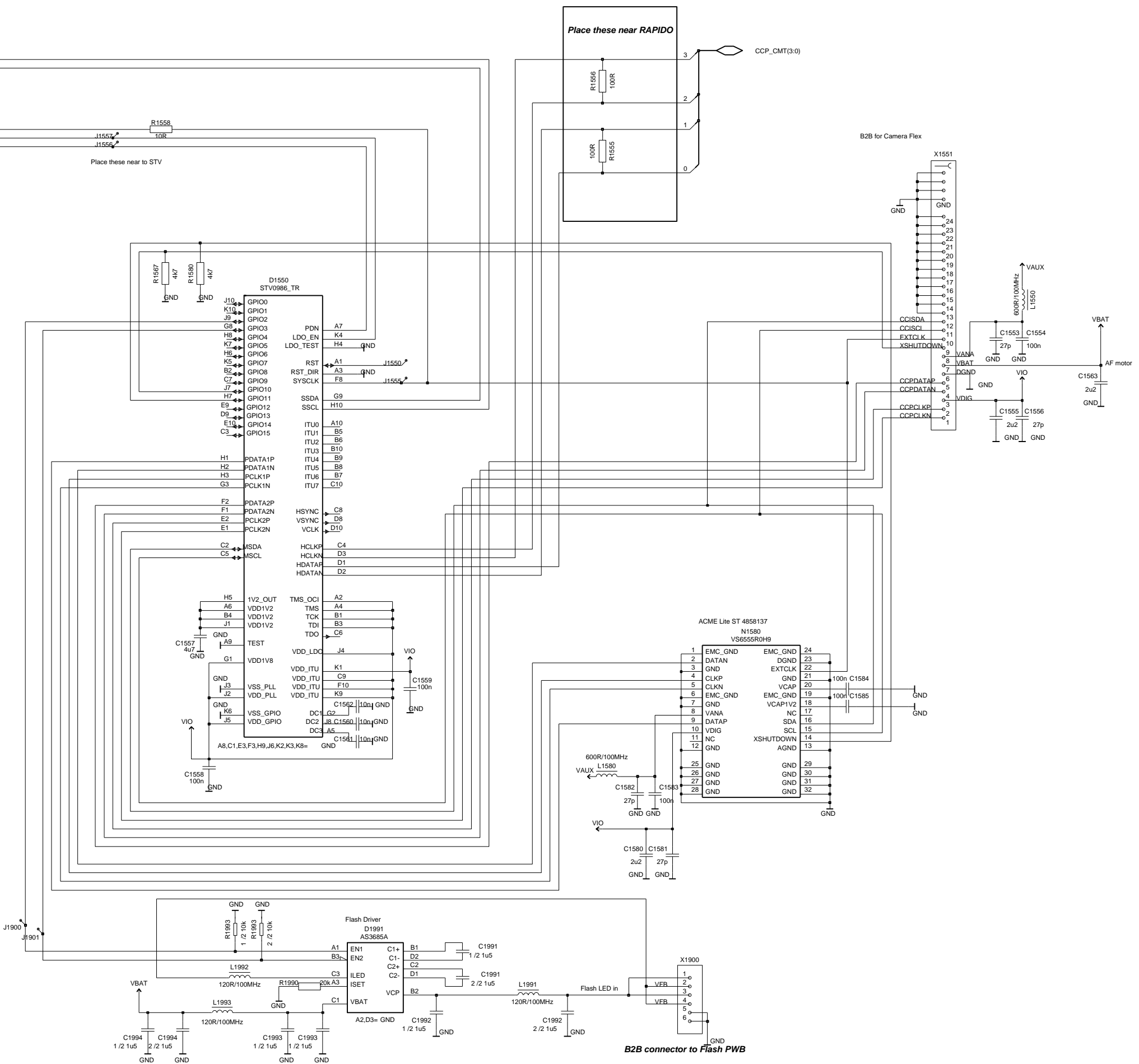

Copyright (C) Nokia Corporation. All rights reserved.  
 THIS DRAWING IS PROTECTED BY COPYRIGHT AS AN UNPUBLISHED WORK.  
 UNAUTHORIZED REPRODUCTION OF THIS DRAWING IS NOT PERMITTED.  
 THIS DRAWING CONTAINS PROPRIETARY AND CONFIDENTIAL INFORMATION.  
 This document is property of Nokia Corporation



Name	Appr		dd-mmm-yy
Assoc	Des.		
File	Dr.		
Proj	Sheet xx of yy	0 (01)	
Draw.	Print Yes	V. 0.0	Edit 52

### Power key

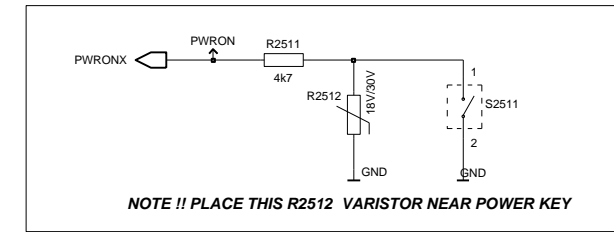

### DIGITAL AMBIENT LIGHT SENSOR

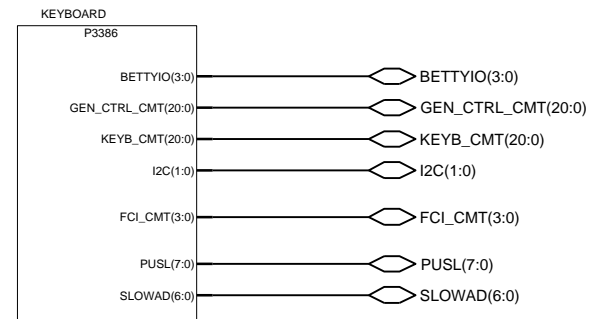
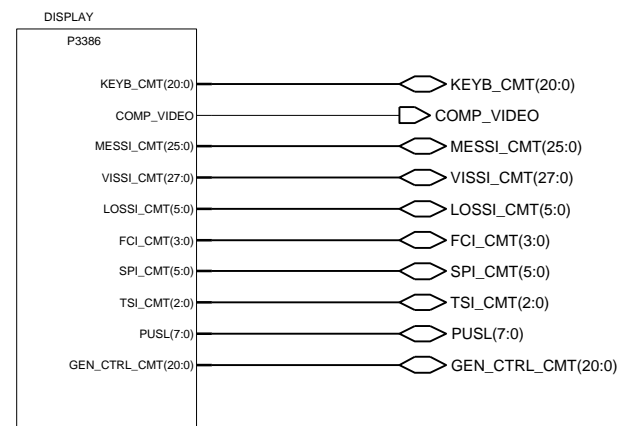
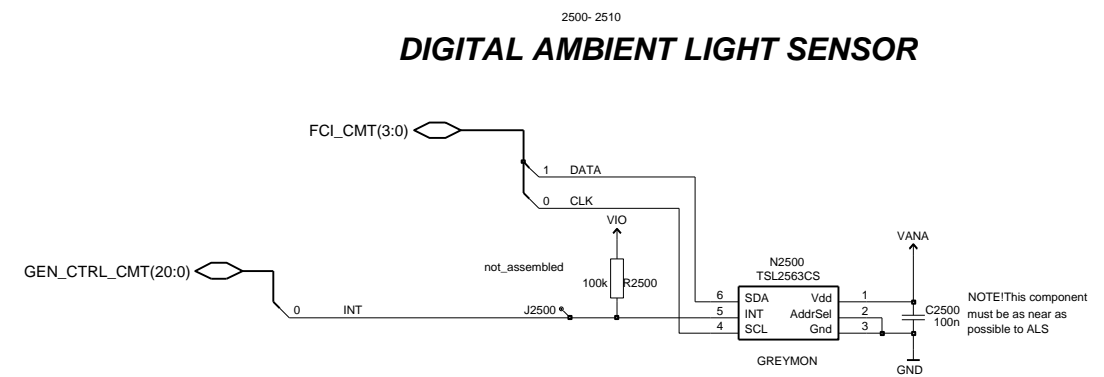

2520-2599

2450-2500

- SLOWAD(6:0)
- SIM(6:0)
- MMC(14:0)

Copyright (C) Nokia Corporation. All rights reserved.  
 THIS DRAWING IS PROTECTED BY COPYRIGHT AS AN UNPUBLISHED WORK.  
 UNAUTHORIZED REPRODUCTION OF THIS DRAWING IS NOT PERMITTED.  
 THIS DRAWING CONTAINS PROPRIETARY AND CONFIDENTIAL INFORMATION.  
 This document is property of Nokia Corporation



Name	UI parts	Appr	dd-mmm-yy
Assoc		Des.	
File		Dr.	
Proj		Sheet xx of yy	0 (01)
	Print Yes	v. 0,0	Edit 10

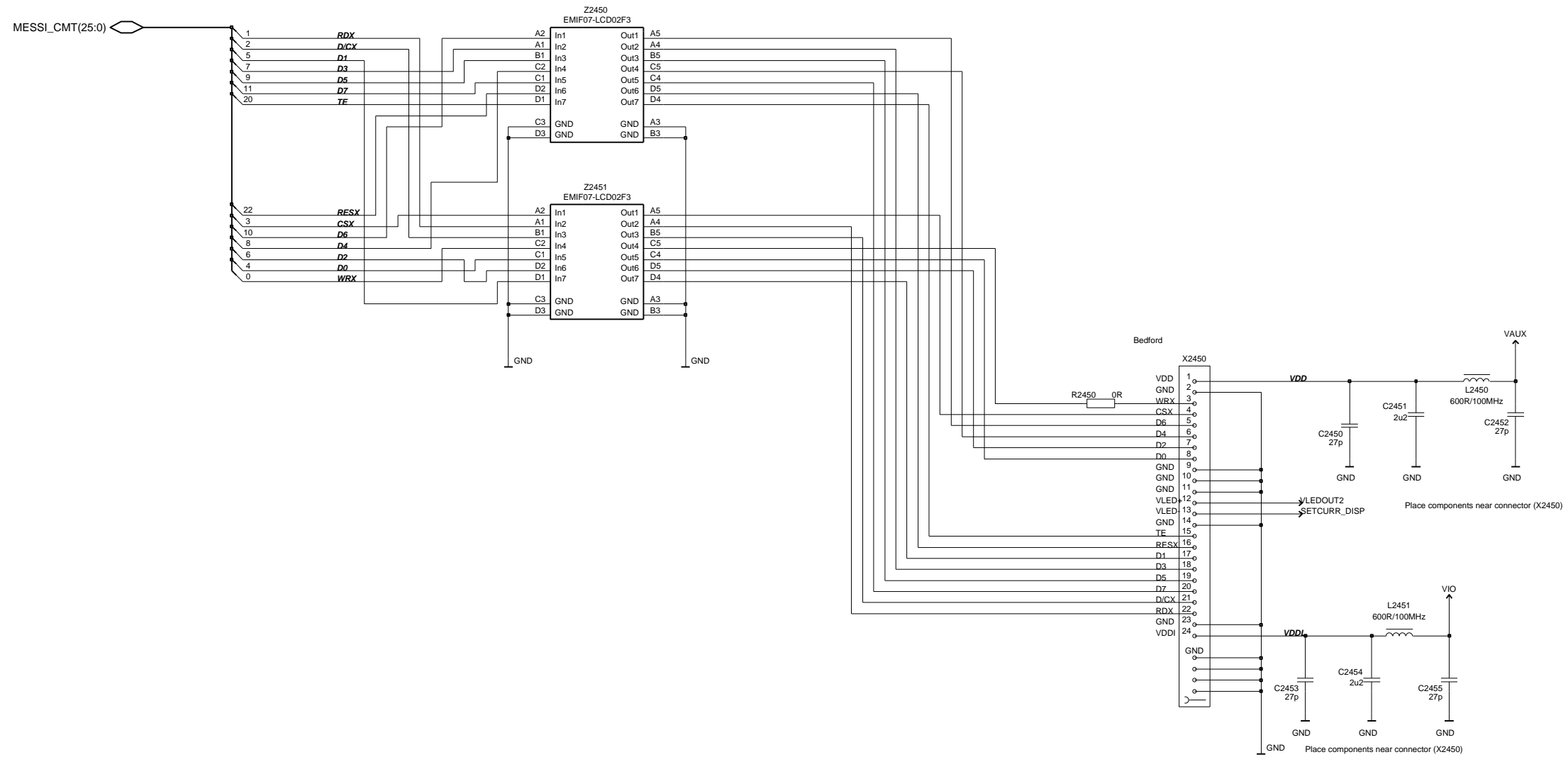

- ⬡ KEYB\_CMT(20:0)
- ⬡ COMP\_VIDEO
- ⬡ MESSI\_CMT(25:0)
- ⬡ VISSI\_CMT(27:0)
- ⬡ LOSSI\_CMT(5:0)
- ⬡ FCI\_CMT(3:0)
- ⬡ SPI\_CMT(5:0)
- ⬡ TSI\_CMT(2:0)
- ⬡ PUSL(7:0)
- ⬡ GEN\_CTRL\_CMT(20:0)

Copyright (C) Nokia Corporation. All rights reserved.  
 THIS DRAWING IS PROTECTED BY COPYRIGHT AS AN UNPUBLISHED WORK.  
 UNAUTHORIZED REPRODUCTION OF THIS DRAWING IS NOT PERMITTED.  
 THIS DRAWING CONTAINS PROPRIETARY AND CONFIDENTIAL INFORMATION.  
 This document is property of Nokia Corporation



Name	display	Appr	dd-mmm-yy
Assoc		Des.	
File		Dr.	
Proj		Sheet xx of yy	0 (01)
		Print Yes	V. 0,0 Edit 8

- I2C(1:0)
- KEYB\_CMT(20:0)
- KEYB\_CMT(20:0)
- GEN\_CTRL\_CMT(20:0)

COLS

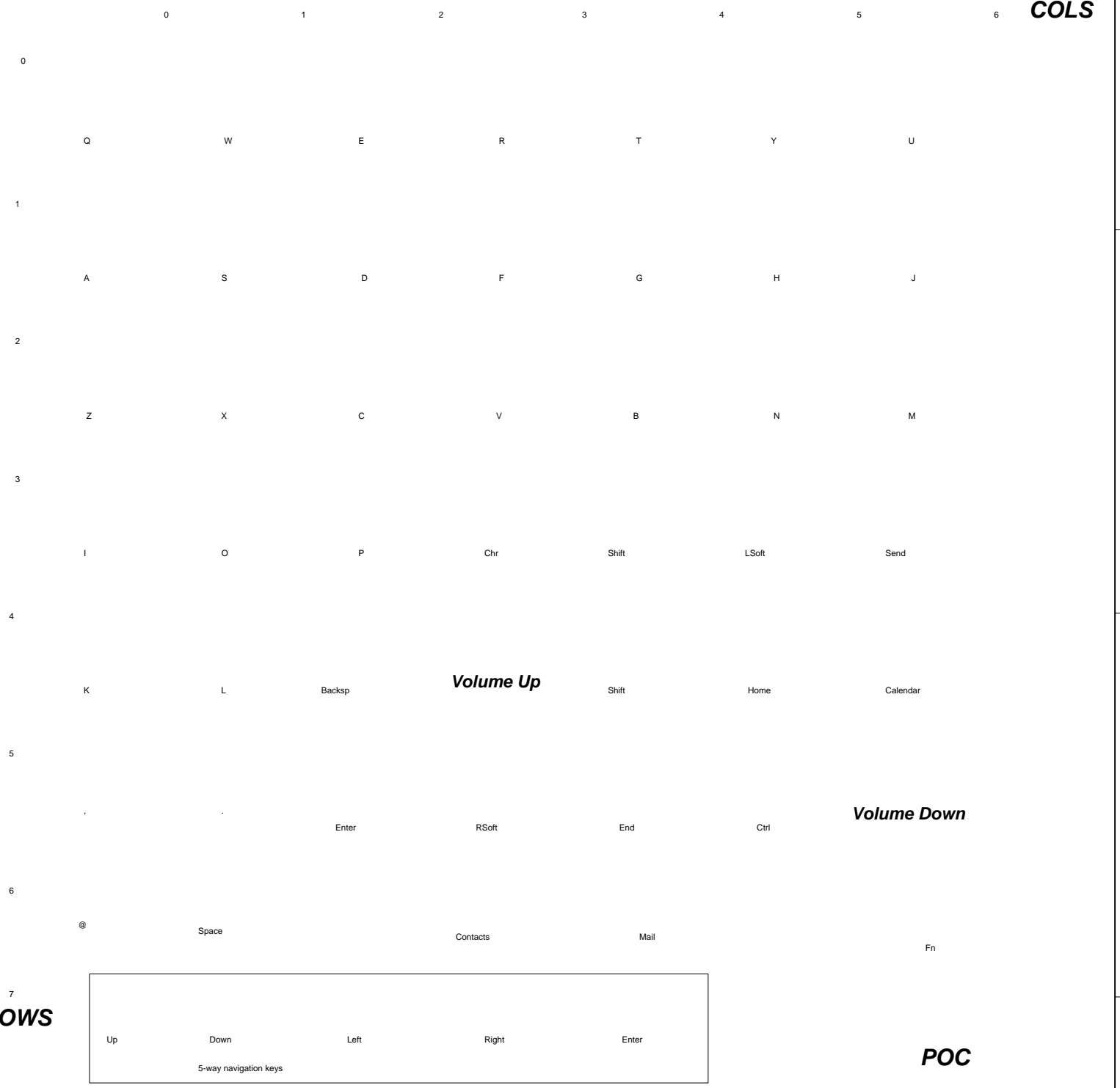
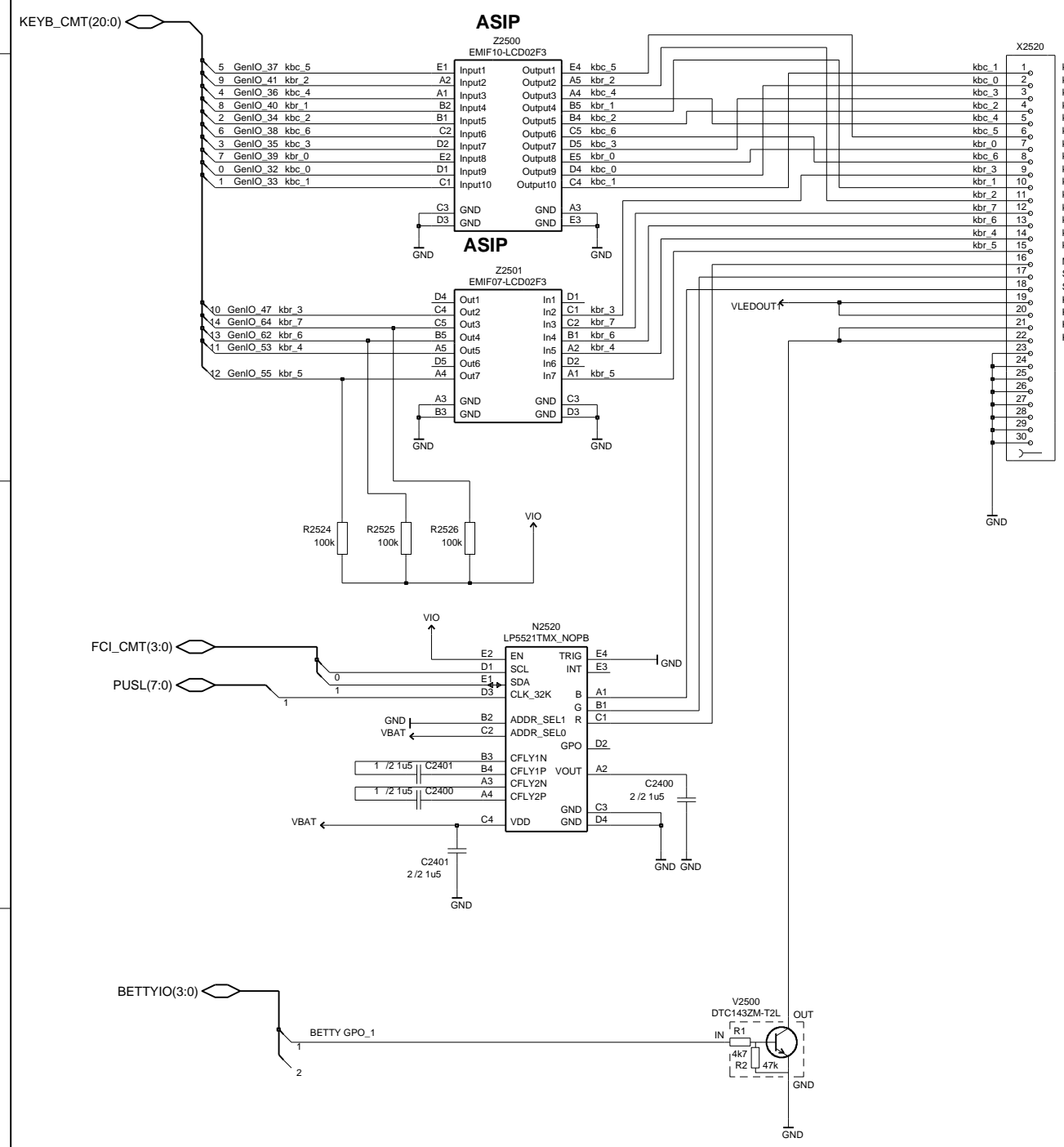

Copyright (C) Nokia Corporation. All rights reserved.  
 THIS DRAWING IS PROTECTED BY COPYRIGHT AS AN UNPUBLISHED WORK.  
 UNAUTHORIZED REPRODUCTION OF THIS DRAWING IS NOT PERMITTED.  
 THIS DRAWING CONTAINS PROPRIETARY AND CONFIDENTIAL INFORMATION.  
 This document is property of Nokia Corporation



Name				Appr	dd-mmm-yy
Assoc				Des.	
File				Dr.	
Proj				Sheet	xx of yy
				Print	Yes v. 0,0
				Edit	22

0 (01)

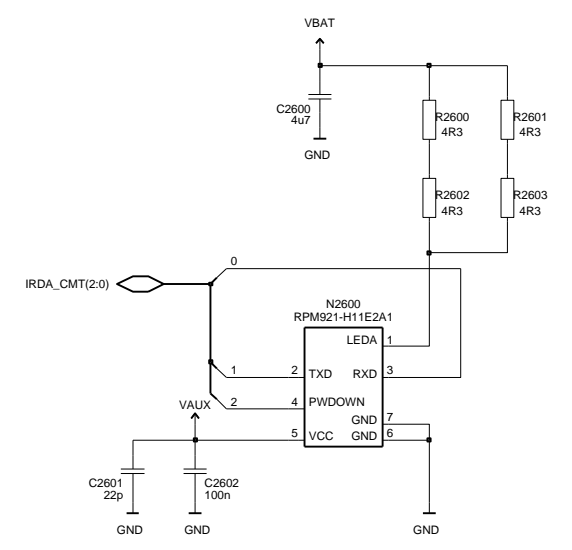

Copyright (C) Nokia Corporation. All rights reserved.  
 THIS DRAWING IS PROTECTED BY COPYRIGHT AS AN UNPUBLISHED WORK.  
 UNAUTHORIZED REPRODUCTION OF THIS DRAWING IS NOT PERMITTED.  
 THIS DRAWING CONTAINS PROPRIETARY AND CONFIDENTIAL INFORMATION.  
 This document is property of Nokia Corporation



Name	IRDA	Appr	dd-mmm-yy
Assoc		Des.	
File		Dr.	
Proj		Sheet xx of yy	0 (01)
	Draw.	Print Yes	v. 0.0 Edit 4

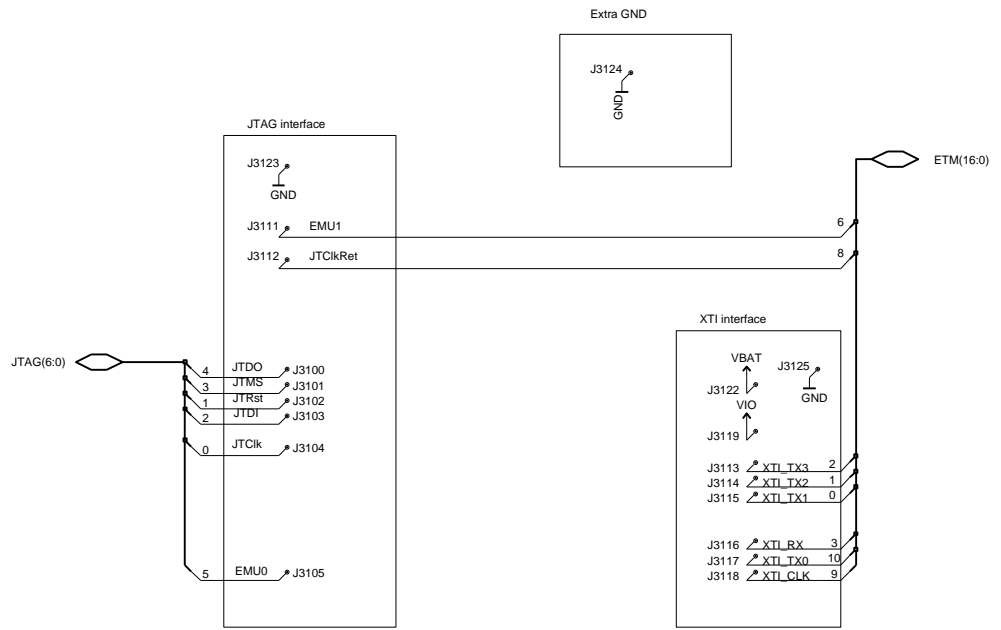

- ⬡ LPRF\_CMT(7:0)
- ⬡ WLAN\_CMT(7:0)
- ⬡ USB\_AC(7:0)
- ⬡ SLOWAD(6:0)
- ⬡ GEN\_CTRL\_CMT(20:0)
- ⬡ JTAG(6:0)
- ⬡ ETM(16:0)
- ⬡ PCM(3:0)
- ⬡ PUSL(7:0)
- ⬡ WLAN\_BT(6:0)

Copyright (C) Nokia Corporation. All rights reserved.  
 THIS DRAWING IS PROTECTED BY COPYRIGHT AS AN UNPUBLISHED WORK.  
 UNAUTHORIZED REPRODUCTION OF THIS DRAWING IS NOT PERMITTED.  
 THIS DRAWING CONTAINS PROPRIETARY AND CONFIDENTIAL INFORMATION.  
 This document is property of Nokia Corporation



Name	emu engine	Appr	dd-mmm-yy
Assoc		Des.	
File		Dr.	
Proj		Sheet xx of yy	0 (01)
	Print Yes	v. 0,0	Edit 2

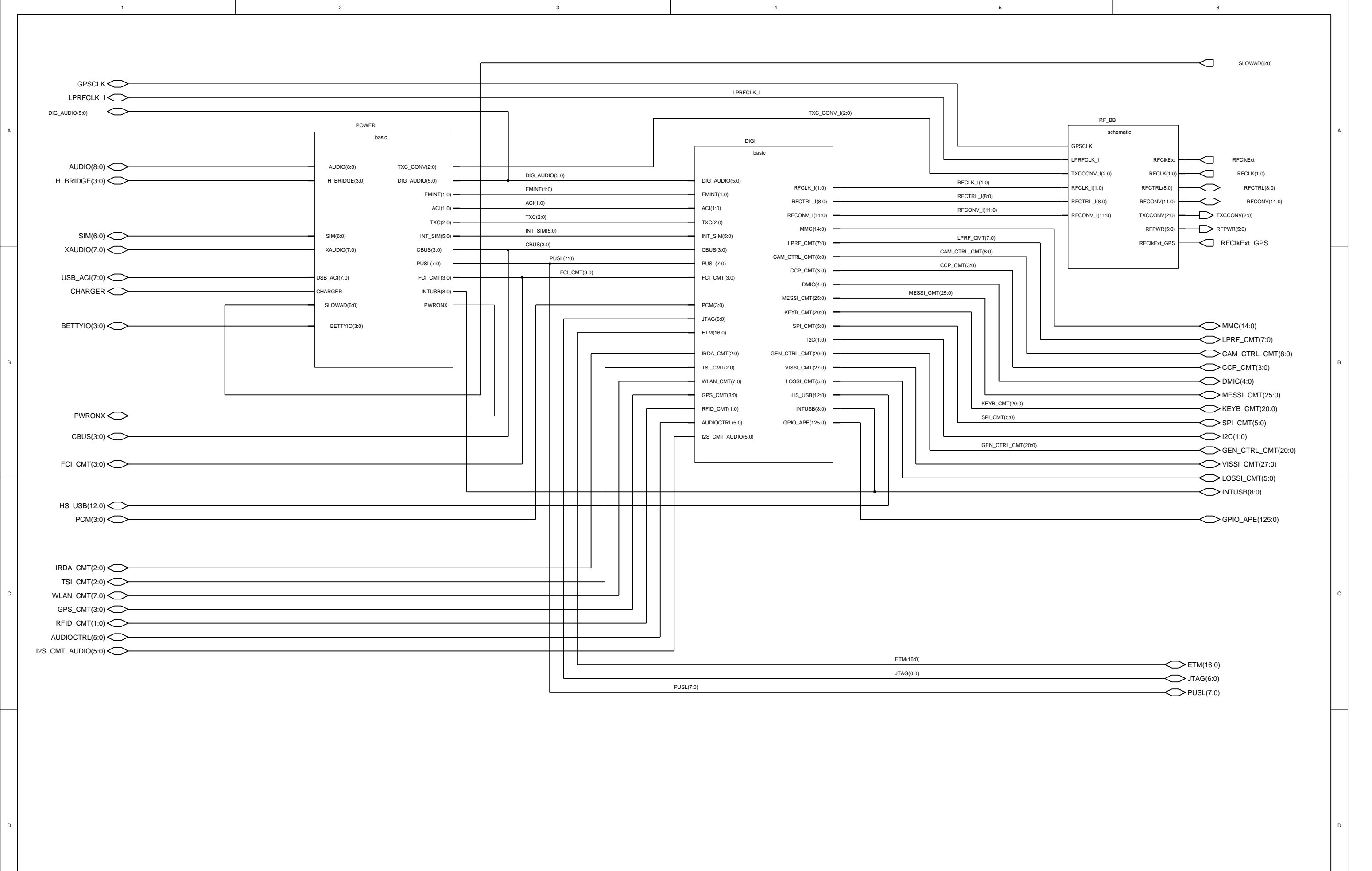

Copyright (C) Nokia Corporation. All rights reserved.  
 THIS DRAWING IS PROTECTED BY COPYRIGHT AS AN UNPUBLISHED WORK.  
 UNAUTHORIZED REPRODUCTION OF THIS DRAWING IS NOT PERMITTED.  
 THIS DRAWING CONTAINS PROPRIETARY AND CONFIDENTIAL INFORMATION.  
 This document is property of Nokia Corporation



Name	CMT_Engine Top level		Appr	dd-mmm-yy
Assoc			Des.	
File			Dr.	
Proj			Sheet	xx of yy
			Print	Yes
			V.	0,0
			Edit	4
				0 (01)

CBB5X

TOP SHEET

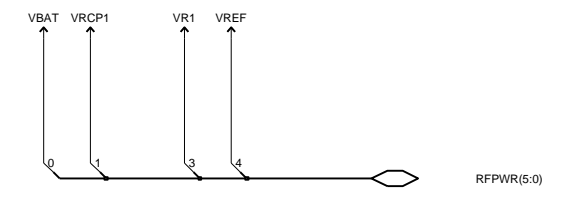
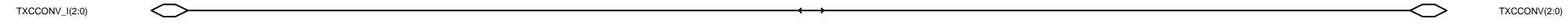
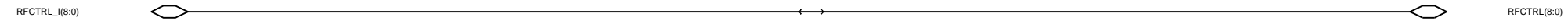
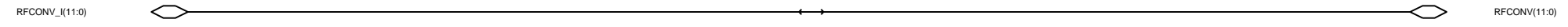
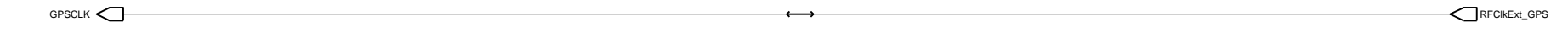
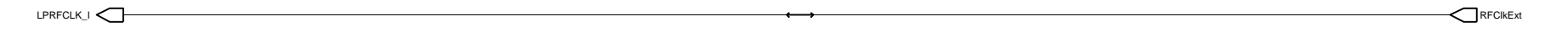
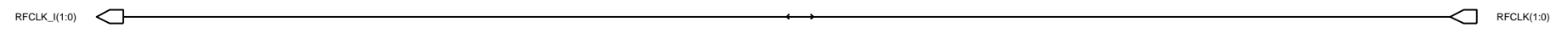

Copyright (C) Nokia Corporation. All rights reserved.  
 THIS DRAWING IS PROTECTED BY COPYRIGHT AS AN UNPUBLISHED WORK.  
 UNAUTHORIZED REPRODUCTION OF THIS DRAWING IS NOT PERMITTED.  
 THIS DRAWING CONTAINS PROPRIETARY AND CONFIDENTIAL INFORMATION.  
 This document is property of Nokia Corporation



Name RF IF		Appr dd-mmm-yy	
Assoc		Des.	
File		Dr.	
Proj		Sheet xx of yy	0 (01)
Draw.		Print Yes v. 0	Edit 2

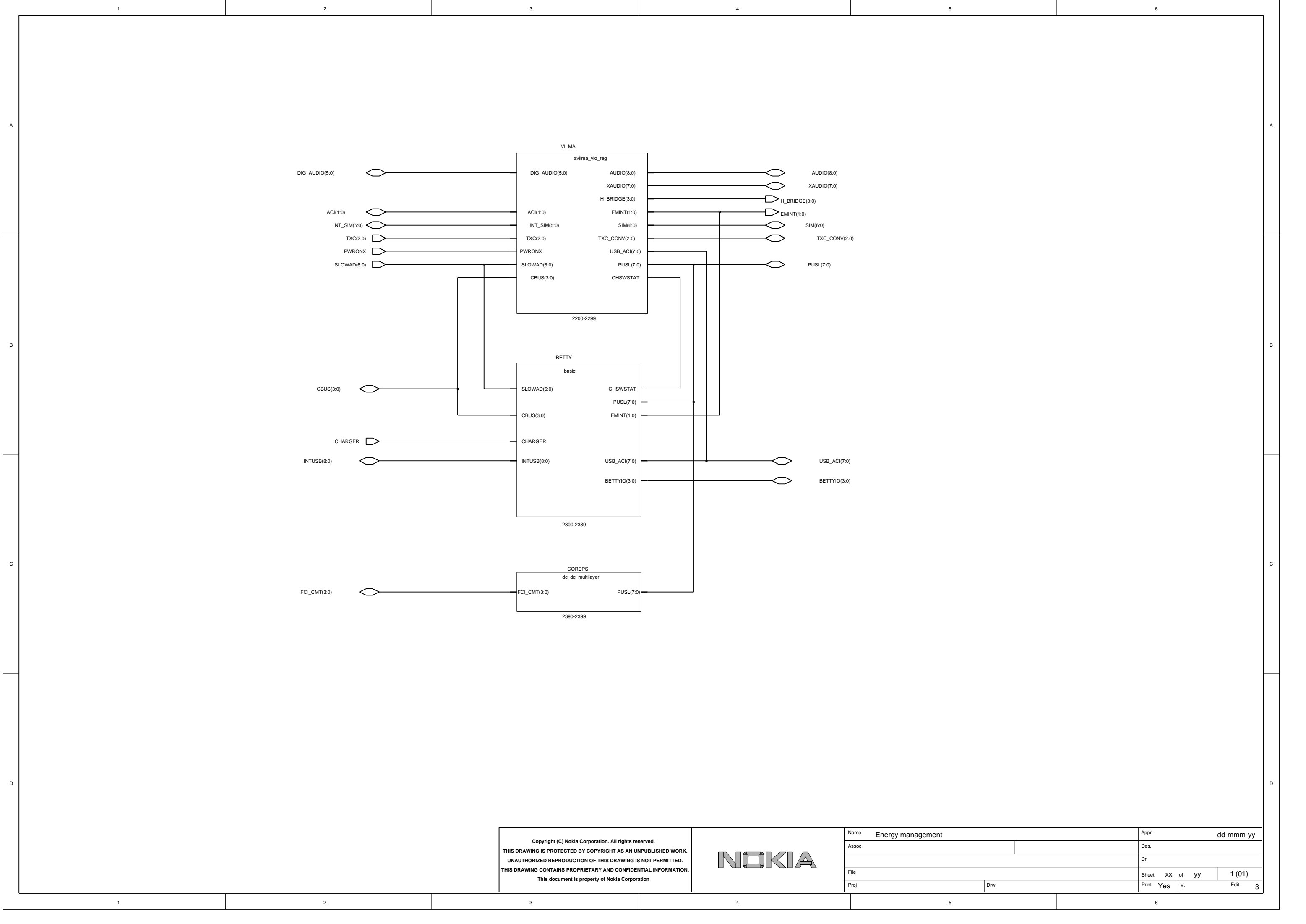

Copyright (C) Nokia Corporation. All rights reserved.  
 THIS DRAWING IS PROTECTED BY COPYRIGHT AS AN UNPUBLISHED WORK.  
 UNAUTHORIZED REPRODUCTION OF THIS DRAWING IS NOT PERMITTED.  
 THIS DRAWING CONTAINS PROPRIETARY AND CONFIDENTIAL INFORMATION.  
 This document is property of Nokia Corporation



Name Energy management		Appr dd-mmm-yy	
Assoc		Des.	
File		Dr.	
Proj		Sheet xx of yy	1 (01)
Draw.		Print Yes v.	Edit 3

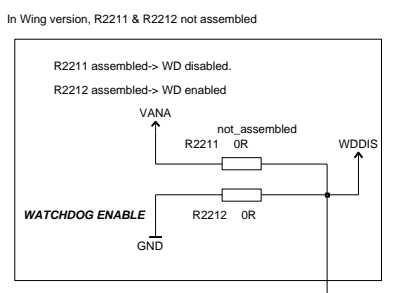
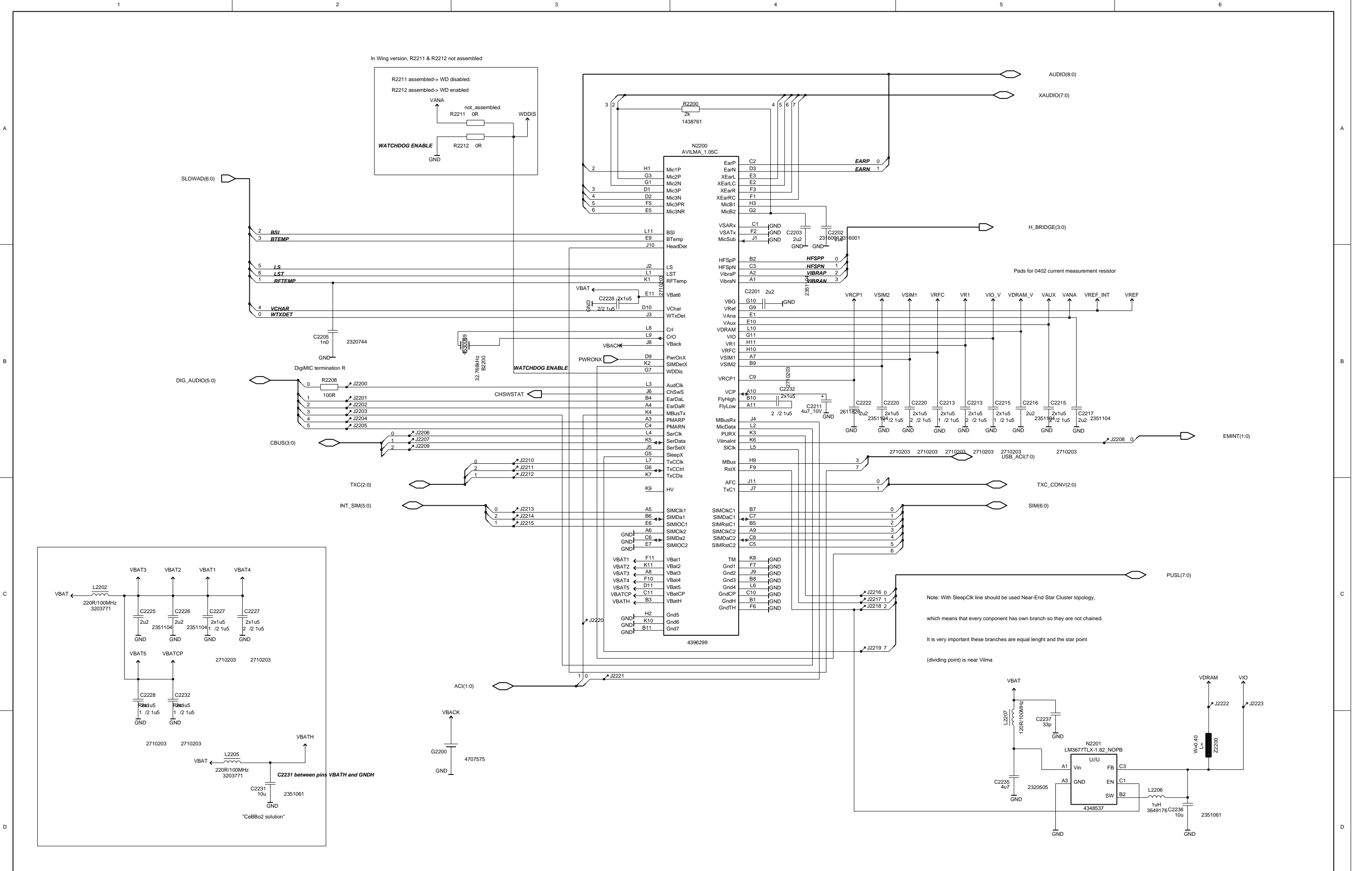

Note: With SleepClk line should be used Near-End Star Cluster topology, which means that every component has own branch so they are not chained. It is very important these branches are equal length and the star point (dividing point) is near Vilma

Copyright (C) Nokia Corporation. All rights reserved.  
THIS DRAWING IS PROTECTED BY COPYRIGHT AS AN UNPUBLISHED WORK.  
UNAUTHORIZED REPRODUCTION OF THIS DRAWING IS NOT PERMITTED.  
THIS DRAWING CONTAINS PROPRIETARY AND CONFIDENTIAL INFORMATION.  
This document is property of Nokia Corporation



Name	AVILMA + External Vio SMPS	Appr	dd-mmm-yy
Assoc		Des.	
File		Dr.	
Proj		Sheet	xx of yy
		Print	Yes
		V.	0.0
		Edit	15

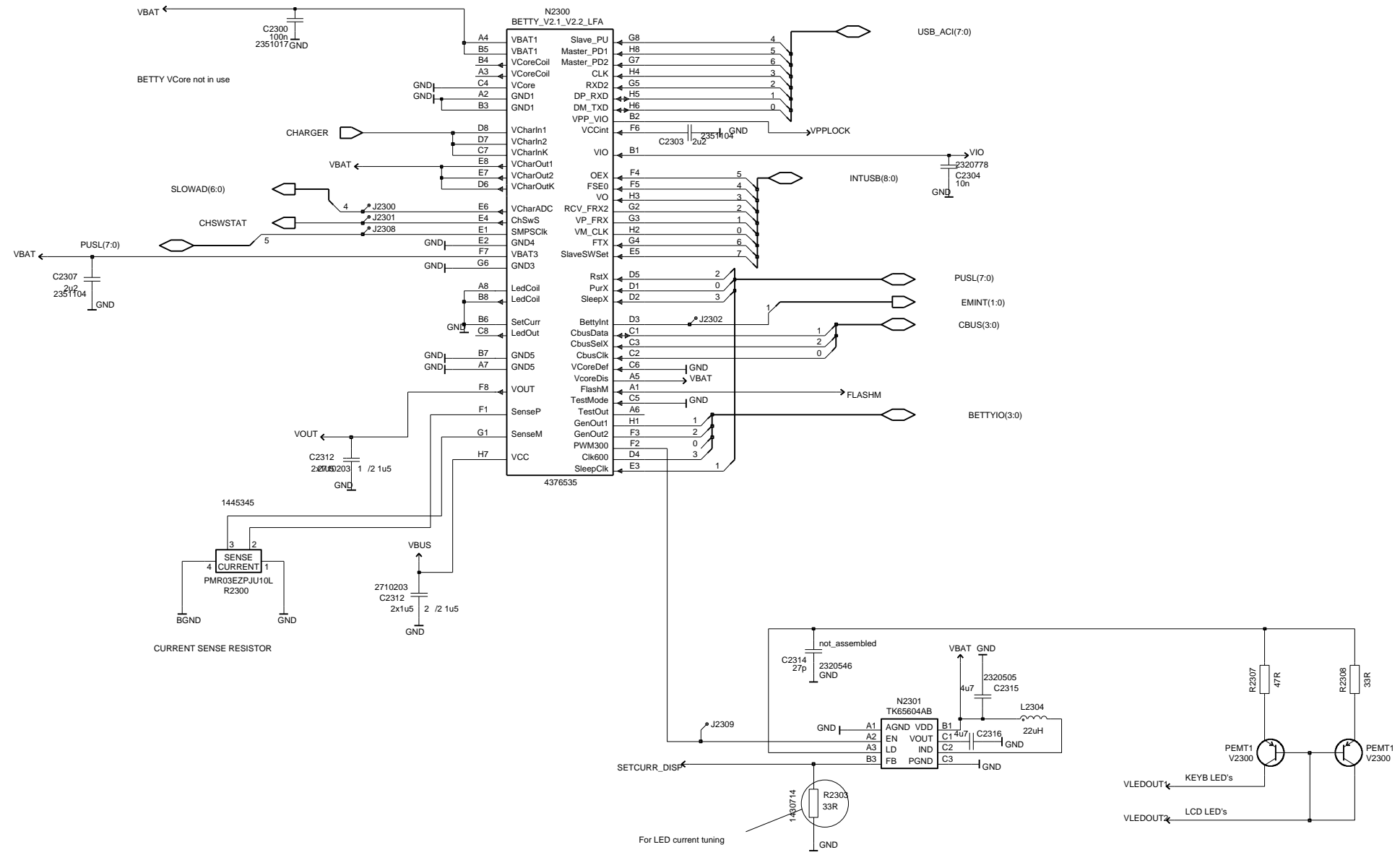

Copyright (C) Nokia Corporation. All rights reserved.  
 THIS DRAWING IS PROTECTED BY COPYRIGHT AS AN UNPUBLISHED WORK.  
 UNAUTHORIZED REPRODUCTION OF THIS DRAWING IS NOT PERMITTED.  
 THIS DRAWING CONTAINS PROPRIETARY AND CONFIDENTIAL INFORMATION.  
 This document is property of Nokia Corporation



Name	Betty	Appr	10-Aug-00
Assoc		Des.	
File		Dr.	
Proj		Sheet XX of yy	1 (01)
	Draw.	Print Yes	v. Edit 13

NOTE! SDA and SCL lines should include 10-47kOhm pull up resistors. Resistors value is dependent on number of I2C slaves

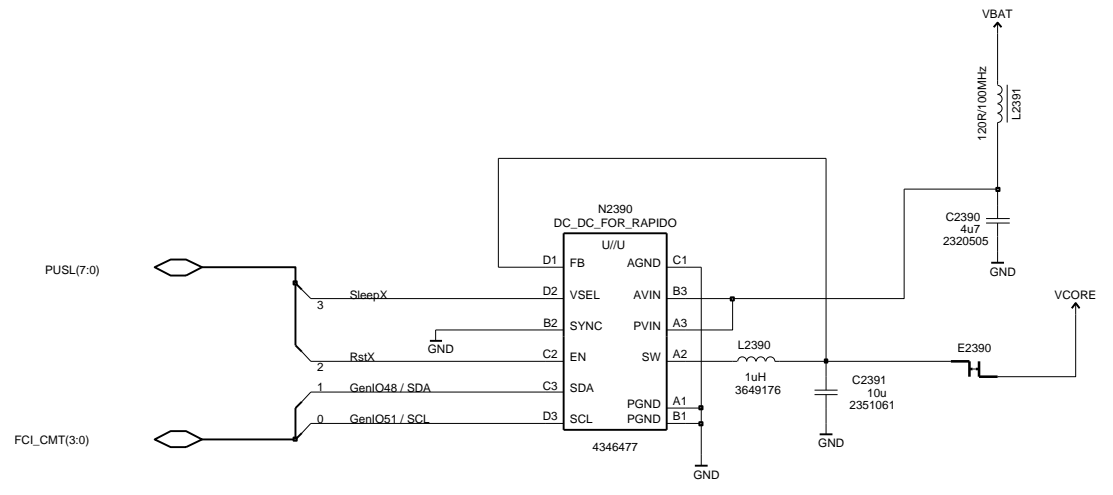

Copyright (C) Nokia Corporation. All rights reserved.  
 THIS DRAWING IS PROTECTED BY COPYRIGHT AS AN UNPUBLISHED WORK.  
 UNAUTHORIZED REPRODUCTION OF THIS DRAWING IS NOT PERMITTED.  
 THIS DRAWING CONTAINS PROPRIETARY AND CONFIDENTIAL INFORMATION.  
 This document is property of Nokia Corporation



Name	RAPIDO VCORE SMPS with multilayer coil		Appr	dd-mmm-yy
Assoc			Des.	
File			Dr.	
Proj	Drw.		Sheet xx of yy	0 (01)
	Print Yes	V. 0,0	Edit	10

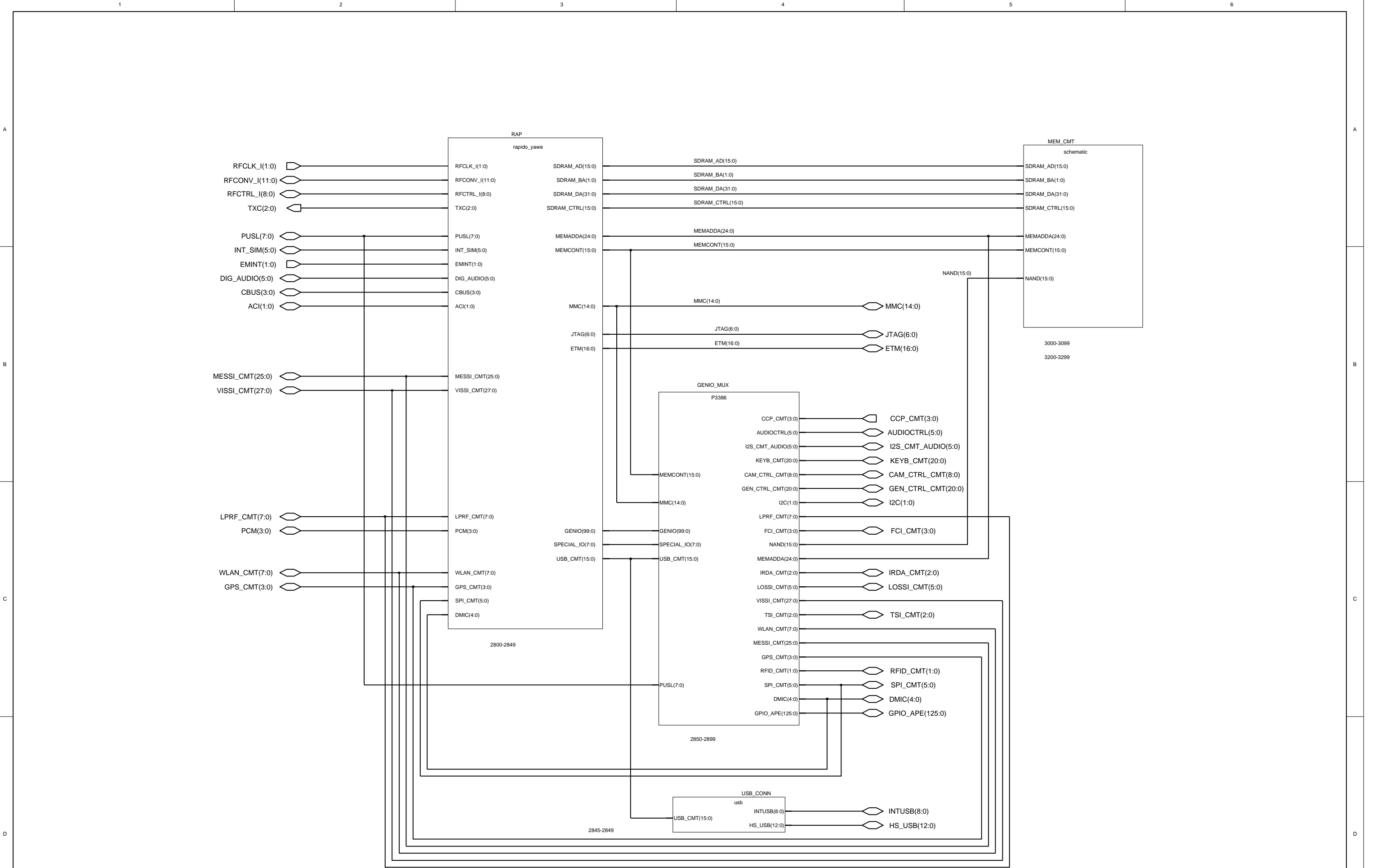

Copyright (C) Nokia Corporation. All rights reserved.  
 THIS DRAWING IS PROTECTED BY COPYRIGHT AS AN UNPUBLISHED WORK.  
 UNAUTHORIZED REPRODUCTION OF THIS DRAWING IS NOT PERMITTED.  
 THIS DRAWING CONTAINS PROPRIETARY AND CONFIDENTIAL INFORMATION.  
 This document is property of Nokia Corporation



Name		CMT SUBSYSTEM		Appr		dd-mmm-yy	
Assoc				Des.			
File				Dr.			
Proj				Sheet xx of yy		0 (01)	
Print		Yes		v. 0		Edit 5	

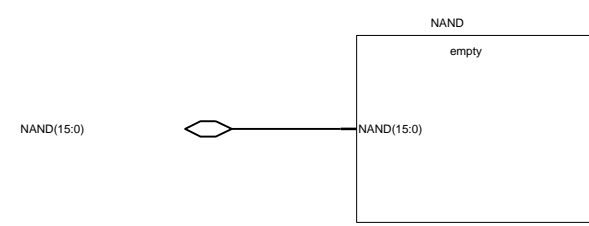
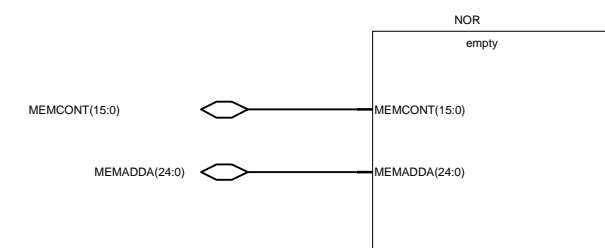
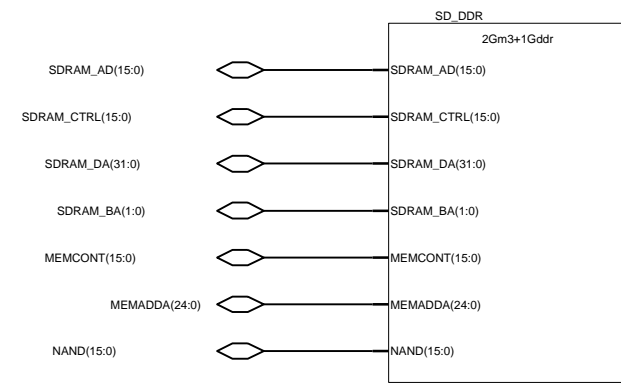

Copyright (C) Nokia Corporation. All rights reserved.  
 THIS DRAWING IS PROTECTED BY COPYRIGHT AS AN UNPUBLISHED WORK.  
 UNAUTHORIZED REPRODUCTION OF THIS DRAWING IS NOT PERMITTED.  
 THIS DRAWING CONTAINS PROPRIETARY AND CONFIDENTIAL INFORMATION.  
 This document is property of Nokia Corporation



Name	CMT Memories	Appr	10-Aug-00
Assoc		Des.	
File		Dr.	
Proj		Sheet	xx of yy
		Print	Yes
		v.	02
		Edit	3
			1 (01)

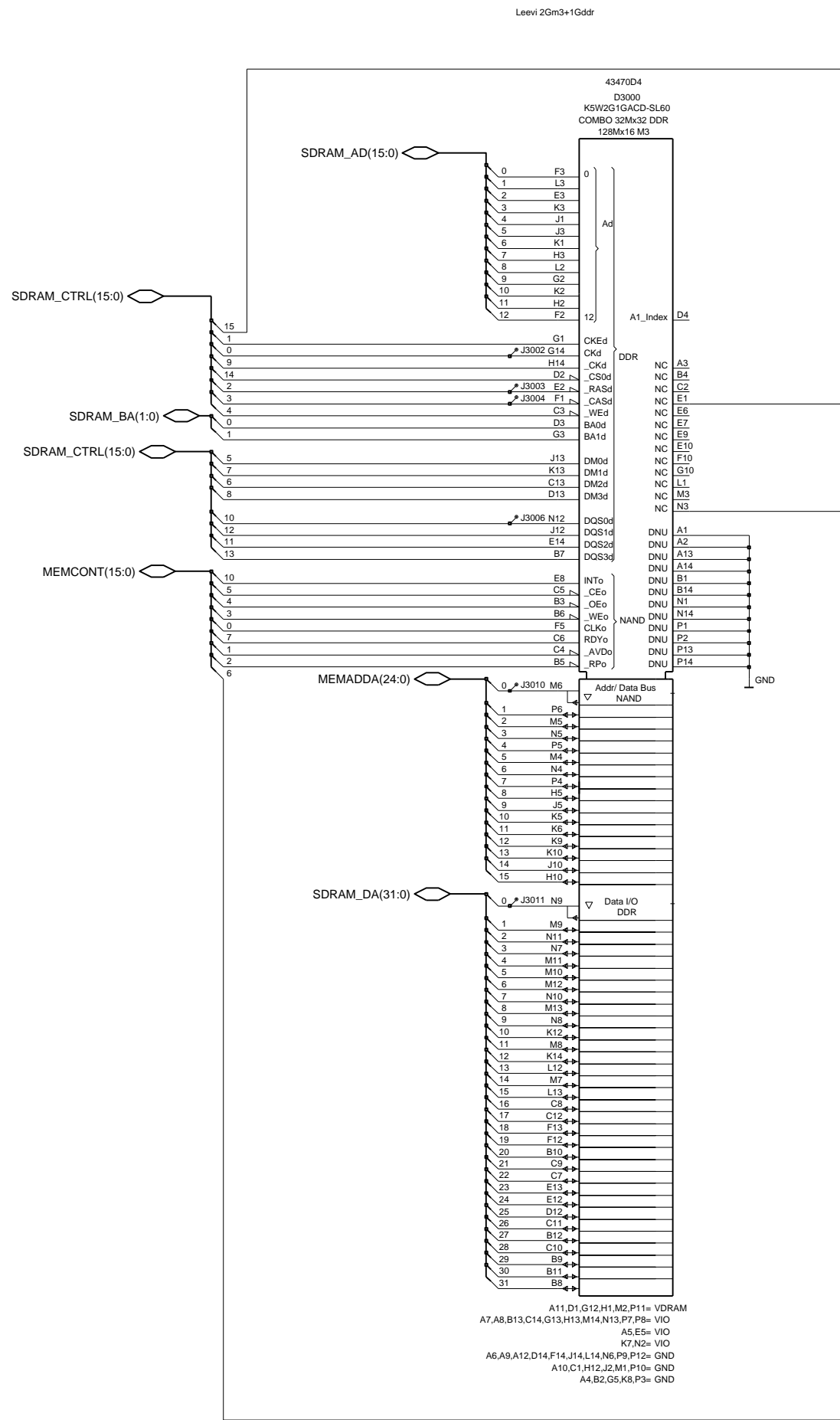
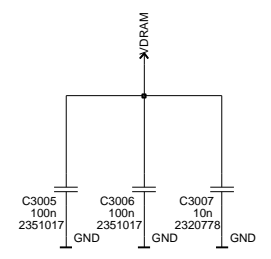
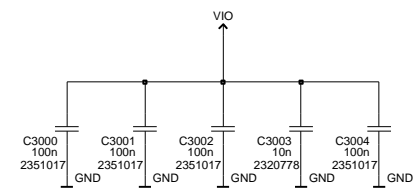

NAND(15:0)

Copyright (C) Nokia Corporation. All rights reserved.  
 THIS DRAWING IS PROTECTED BY COPYRIGHT AS AN UNPUBLISHED WORK.  
 UNAUTHORIZED REPRODUCTION OF THIS DRAWING IS NOT PERMITTED.  
 THIS DRAWING CONTAINS PROPRIETARY AND CONFIDENTIAL INFORMATION.  
 This document is property of Nokia Corporation

Name Combo memory M3 2G + DDR 1G  
 Appr dd-mmm-yy

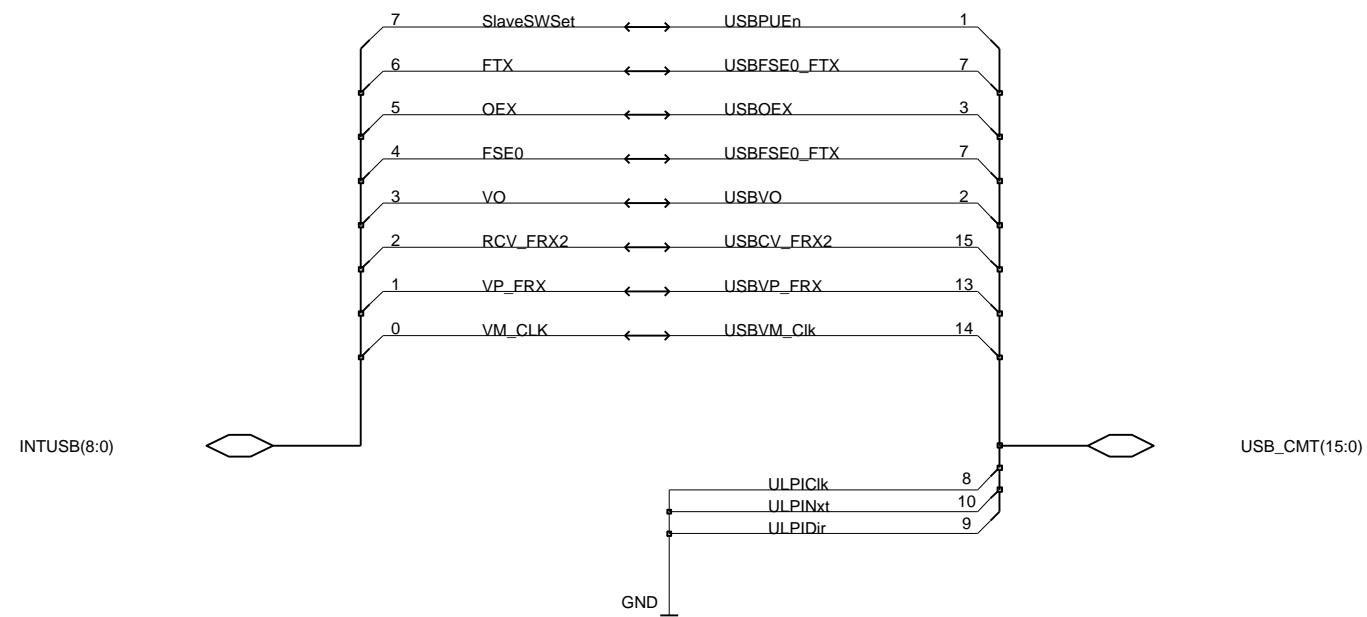

HS\_USB(12:0)



Copyright (C) Nokia Corporation. All rights reserved.  
 THIS DRAWING IS PROTECTED BY COPYRIGHT AS AN UNPUBLISHED WORK.  
 UNAUTHORIZED REPRODUCTION OF THIS DRAWING IS NOT PERMITTED.  
 THIS DRAWING CONTAINS PROPRIETARY AND CONFIDENTIAL INFORMATION.  
 This document is property of Nokia Corporation



Name USB		Appr dd-mmm-yy	
Assoc		Des.	
		Dr.	
File		Sheet XX of yy	0 (01)
Proj	Drw.	Print Yes	V. 0.0 Edit 4

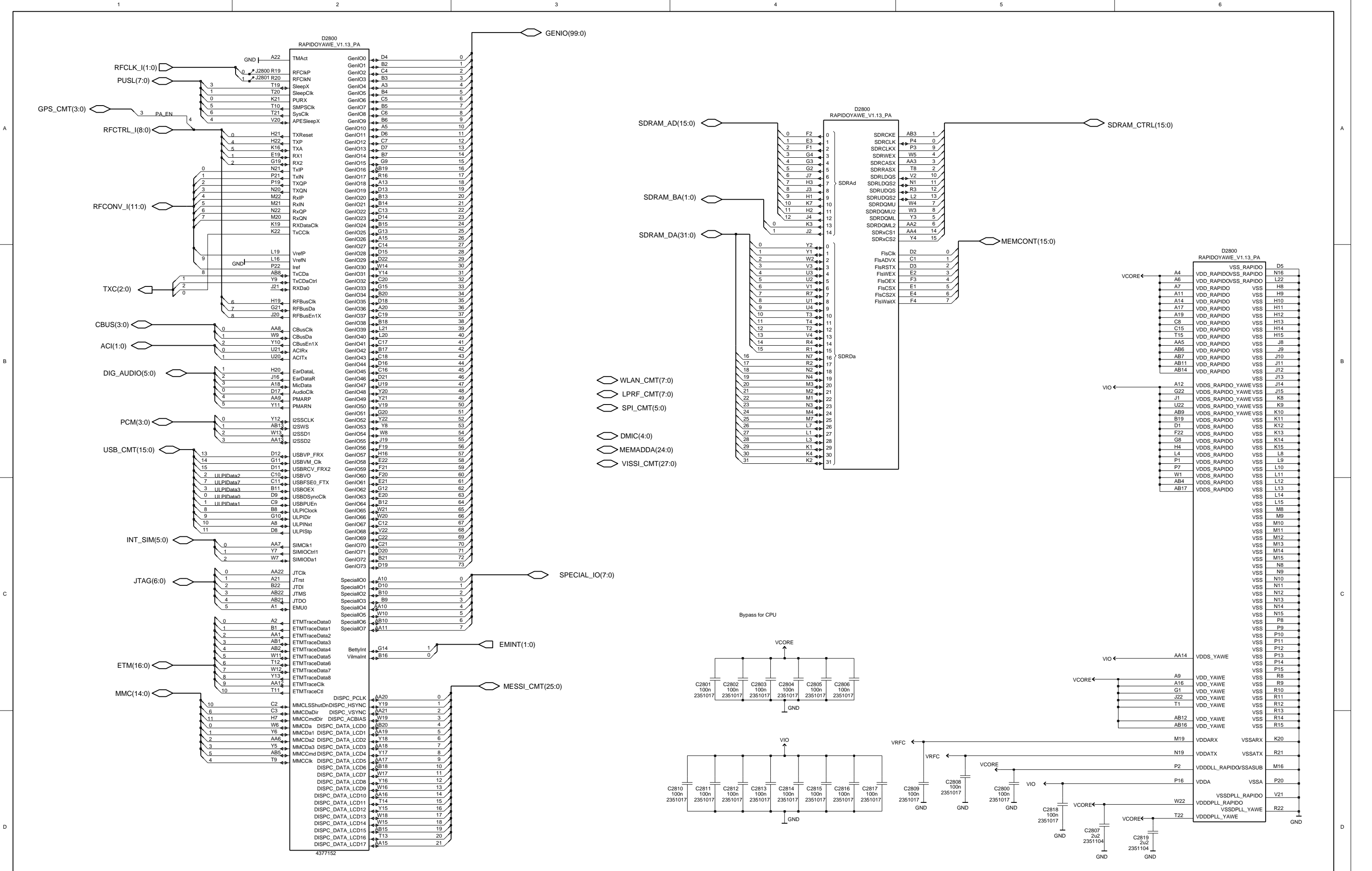

Copyright (C) Nokia Corporation. All rights reserved.  
 THIS DRAWING IS PROTECTED BY COPYRIGHT AS AN UNPUBLISHED WORK.  
 UNAUTHORIZED REPRODUCTION OF THIS DRAWING IS NOT PERMITTED.  
 THIS DRAWING CONTAINS PROPRIETARY AND CONFIDENTIAL INFORMATION.  
 This document is property of Nokia Corporation



Name	RAPIDO YAWE		Appr	dd-mmm-yy
Assoc			Des.	
File			Dr.	
Proj			Sheet	xx of yy
			Print	Yes
			Version	v. 0.0
			Edit	10
			0 (01)	

- 0 genio0 MEMADDA0
- 1 genio1 MEMADDA1
- 2 genio2 MEMADDA2
- 3 genio3 MEMADDA3
- 4 genio4 MEMADDA4
- 5 genio5 MEMADDA5
- 6 genio6 MEMADDA6
- 7 genio7 MEMADDA7
- 8 genio8 MEMADDA8
- 9 genio9 MEMADDA9
- 10 genio10 MEMADDA10
- 11 genio11 MEMADDA11
- 12 genio12 MEMADDA12
- 13 genio13 MEMADDA13
- 14 genio14 MEMADDA14
- 15 genio15 MEMADDA15
- 16 genio16 GPS\_ENABLE
- 17 genio17 AVPlugDet
- 18 genio18 AVPaEn
- 19 genio19 AVECIChI
- 20 genio20 FM\_INT
- 21 genio21 BT\_WAKEUP
- 22 genio22 FlashINT
- 23 genio23 DAL5\_INT
- 24 genio24 MMC\_POS\_DET
- 25 genio25 GPS\_Int
- 26 genio26 NC
- 27 genio27 NC
- 28 genio28 NC
- 29 genio29 WLAN\_IRQ
- 30 genio30 I2C\_SDA
- 31 genio31 I2C\_SCL
- 32 genio32 KEYB\_COL0
- 33 genio33 KEYB\_COL1
- 34 genio34 KEYB\_COL2
- 35 genio35 KEYB\_COL3
- 36 genio36 KEYB\_COL4
- 37 genio37 KEYB\_COL5
- 38 genio38 KEYB\_COL6
- 39 genio39 KEYB\_ROW0
- 40 genio40 KEYB\_ROW1
- 41 genio41 KEYB\_ROW2
- 42 genio42 DMIC\_AuxTxPDM
- 43 genio43 WLAN\_SPI\_DIN
- 44 genio44 LCD\_RSTX
- 45 genio45 MMCDet (Pre-warning)
- 46 genio46 MMCDaDir1
- 47 genio47 KEYB\_ROW3
- 48 genio48 ECISDA
- 49 genio49 STV\_LDO\_EN
- 50 genio50 UARTWAKE
- 51 genio51 ECISCL
- 52 genio52 NC
- 53 genio53 KEYB\_ROW4
- 54 genio54 WLAN\_RESETX
- 55 genio55 KEYB\_ROWS
- 56 genio56 IRRX
- 57 genio57 IRTX
- 58 genio58 IRSD
- 59 genio59 BTDAIN
- 60 genio60 BTDAOUT
- 61 genio61 GPS\_TimeStamp
- 62 genio62 KEYB\_ROW6
- 63 genio63 WLAN\_SPI\_DOUT
- 64 genio64 KEYB\_ROW7
- 65 genio65 BTRSTX
- 66 genio66 STV\_HWA\_PDN
- 67 genio67 NC
- 68 genio68 CAM\_CLK
- 69 genio69 BTCTS
- 70 genio70 BTRTS
- 71 genio71 MMCFbClk
- 72 genio72 WLAN\_SPI\_CLK
- 73 genio73 WLAN\_SPI\_CSX

STV\_LDO\_STBY  
CAM\_REG\_EN

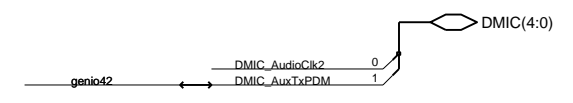
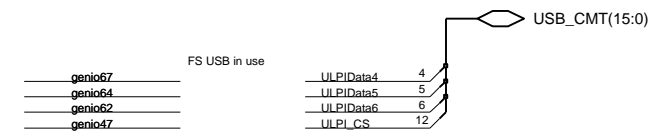
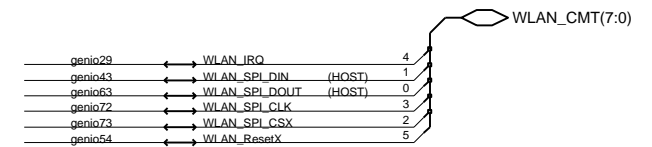
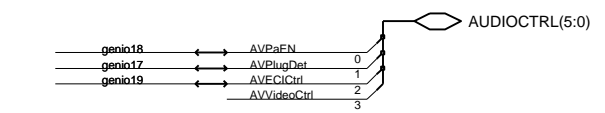
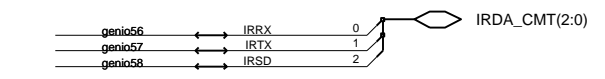
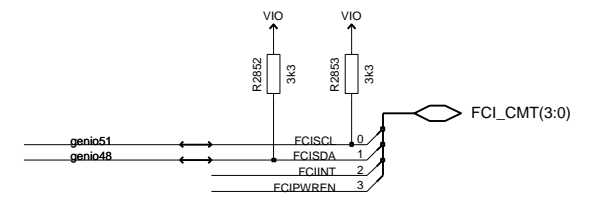
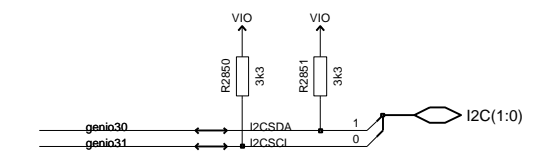
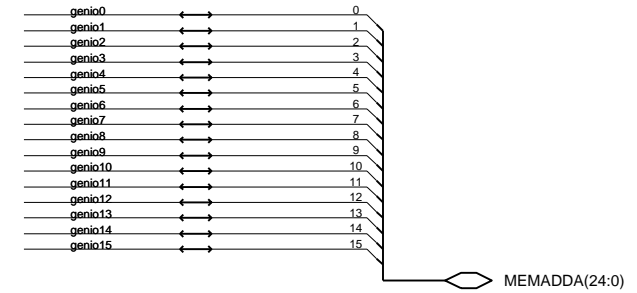
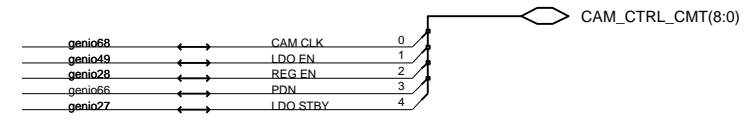
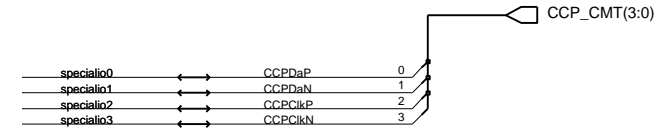
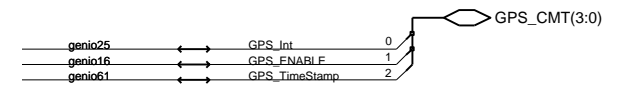
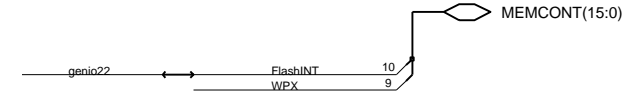
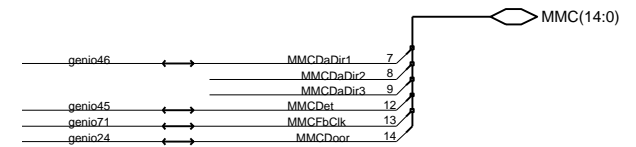
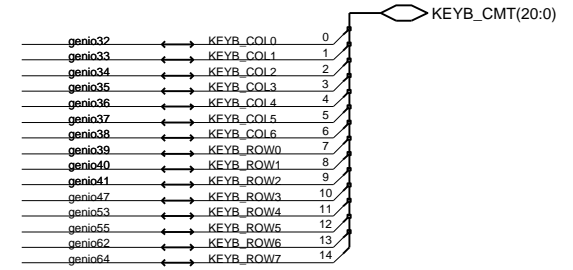

- NAND(15:0)
- LOSSI\_CMT(5:0)
- I2S\_CMT\_AUDIO(5:0)
- VISSI\_CMT(27:0)
- LOSSI\_CMT(5:0)
- TSI\_CMT(2:0)
- SPI\_CMT(5:0)
- RFID\_CMT(1:0)
- GPIO\_APE(125:0)

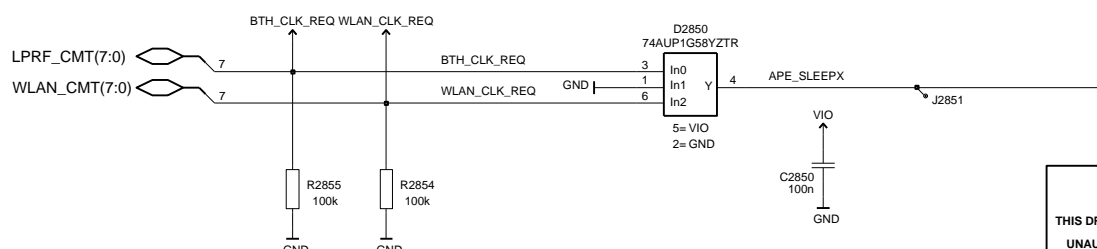
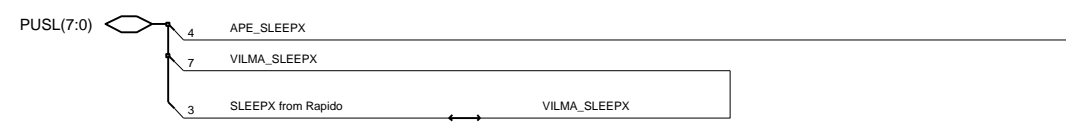
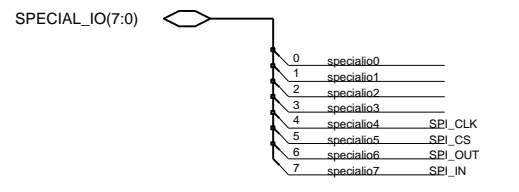

Copyright (C) Nokia Corporation. All rights reserved.  
THIS DRAWING IS PROTECTED BY COPYRIGHT AS AN UNPUBLISHED WORK.  
UNAUTHORIZED REPRODUCTION OF THIS DRAWING IS NOT PERMITTED.  
THIS DRAWING CONTAINS PROPRIETARY AND CONFIDENTIAL INFORMATION.  
This document is property of Nokia Corporation



Name	GenIO mux			Appr
Assoc				Des.
File				Dr.
Proj				0 (01)
Print	Yes	V. 0.0	xx of yy	Edit 21

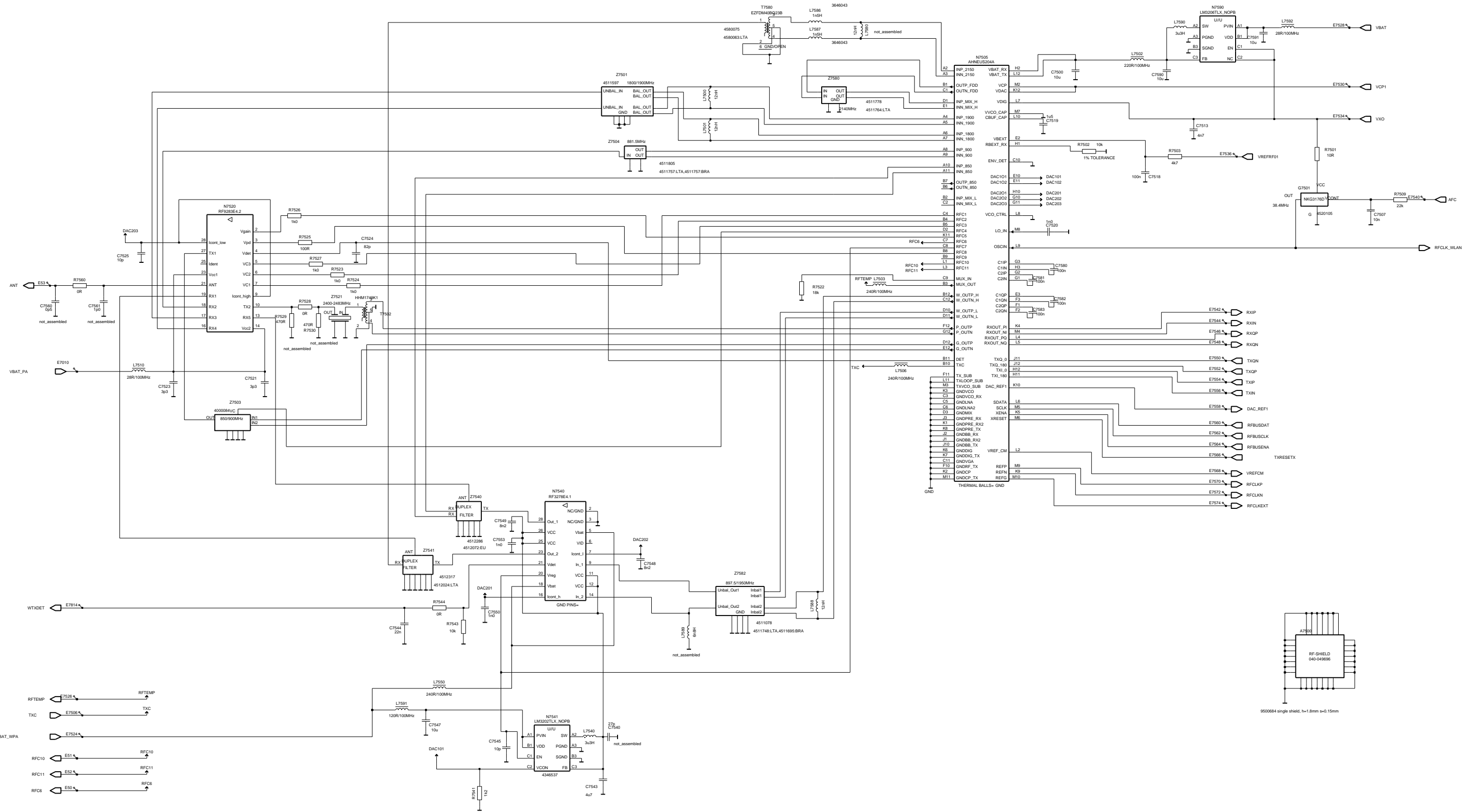

R50\_21

Copyright (C) Nokia Corporation. All rights reserved.  
 THIS DRAWING IS PROTECTED BY COPYRIGHT AS AN UNPUBLISHED WORK.  
 UNAUTHORIZED REPRODUCTION OF THIS DRAWING IS NOT PERMITTED.  
 THIS DRAWING CONTAINS PROPRIETARY AND CONFIDENTIAL INFORMATION.  
 This document is property of Nokia Corporation



Name	r50_engine	Appr	dd-mm-yy
Assoc		Des.	
File		Dr.	
Proj		Sheet	xx of yy
		Print	Yes
		V.	0.0
		Edt	20



